

The Great Lakes RED BOOK—1928

**The
Great Lakes
RED BOOK**

1928

**A list of over 1200 Vessels of
the Great Lakes, together
with the name of Owner,
Captain and Engi-
neer of each Vessel,
Shipbuilding, and
Repair Yards**

Compliments of

The Hardy & Dischinger Co.

Oils and Supplies

Toledo

Ohio

WHITLOCK

PAT'D AUG. 3, 1926. REG. U.S. PAT. OFF.

WATERFLEX

CORDAGE

Thoroughly water-resisting
 Permanently lubricated
 Easy to handle and splice—wet or dry
 Does not swell, harden or kink
 Always remains flexible
 Lasts longer — Serves better
 Costs no more

Write for descriptive folder

WHITLOCK CORDAGE CO.

46 South Street, New York

Factory and Warehouses
 Jersey City, N. J.

Branches
 Chicago, Boston, Kansas City
 and Houston



Fuel Dock
 Clayton, N. Y.

Super-Service

Consaul-Hall Co., Inc.
Agents—Vacuum Oil Co.

Carry bigger cargoes with less
 bunker coal thru the canals
 this year. Get fuel service at
 Clayton and your earnings will
 be larger.

No long waits No short weights

THE ROOT & McBRIDE CO.

Wholesale Dry Goods

We make a study of your special requirements and know how to provide what you need in the following lines.

For Passengers and Crews

Bleached Linen Damasks for Table Cloths	
Colored Damasks for Table Cloths	
Cotton, Part Wool and All Wool Blankets	
White and Colored Sheets	
Mosquito Netting	Curtain Materials
Face Towels	Rugs
Bath Towels	Carpets
Roller Towels	Linoleums
Dish Towels	Cocoa Mats
Bed Spreads	Wash Cloths
Pillow Cases	Oil Cloth
Pillows	Cheese Cloth
Mattresses	Combs
Ducks and Canvas	Soaps
Comforters	Brushes
Laundry Bags — made from duck	

We are always prepared to submit samples promptly.

Phone or write us when you are ready.

Telephone Main 4405

THE ROOT & McBRIDE CO.
Wholesale Dry Goods
 1250 West 6th St. Cleveland, Ohio

A LIST
 OF
OVER 1200 VESSELS
 OF THE
GREAT LAKES
 with the name of
OWNER, CAPTAIN *and* ENGINEER
of EACH VESSEL

Complete Port Directory
 Complete Shipyard Directory

Copyrighted 1928
 The Penton Publishing Co.

Season of 1928

To find the name of owner, captain or engineer refer to the name of the vessel in the alphabetical list. Following the name of each vessel is a number. The number refers to the fleet to which the vessel belongs, and will be found preceding owner's name in fleet list. Shipyard Directory follows Capacity of Ore Carriers.

Published by
Marine Review
 CLEVELAND



Save By Mail
—Bank Here—

You can bank your money by mail with the Society for Savings just as safely, conveniently, and privately as in person.

Write for complete information, or send first deposit in shape of post office or express money order, check or bank draft.

Resources Over 89 Million Dollars
 Since January 1, 1923 dividends to depositors have been at the rate of 4½% a year.

Incorporated 1849
Society for Savings
In the City of Cleveland

Index to Lake Fleet

Vessel	Fleet No.	Vessel	Fleet No.
Aberdeen	159	Americana	35
Abernethy, John..	232	Andaste	81
Acadia	97	Anderson, John ...	413
Acadian	42	Andrews, Matthew	365
Ace	249	Angeline	70
Acme	116	Anglin, R.	80
A. D.	251	Ann Arbor No. 3....	8
Adams, Cuyler ...	381	Ann Arbor No. 4....	8
Adriatic	295	Ann Arbor No. 5....	8
Adriatic	358	Ann Arbor No. 6....	8
Advance	42	Ann Arbor No. 7....	8
Aetna	244	Anticosti	42
Affleck, B. F.....	300	Arabian	42
Agassiz, R. L. ...	152	Aragon	182
Agoming	181	Arctic	136
Alabama	136	Arcturus	295
Alabama	145	Argenteuil	248
Alaska	257	Argo	262
Alaska	355	Ariel	307
Albatross	7	Arizona	286
Alberta	47	Arlington	236
Alert	26	Arnold, Fanny ...	37
Alfred W.	109	Arthur	355
Algoma	230	Arvida	42
Algomah	191	Ashbay	393
Alice		Ashcroft	42
(see Hibou)		Ashland	347
Alice	305	Ashland	355
Allan, Glen	13	Ashley, J. S.....	198
Allan, Sir Hugh..	159	Ashtabula	145
Allan No. 2	37	Ashtabula	288
Aloha	354	Aspen	408
Alpena	145	Assiniboia	47
Alpena	432	Athabasca	47
Amaranth	408	Atlas	194
Amazon	176	Atterbury, W. W.	146
Amberg, W. A....	157	Atwater, Wm. C.	426
America	14	Aube	231
America	145	Aubrey	7
America	332	Augustus	355
America	404	Augustus, A. A..	176

136th Year

“America’s Oldest Fire and Marine Insurance Company”

FOUNDED 1792

Insurance Company of North America

PHILADELPHIA

Capital - \$7,500,000

Place your business in a company that has proven its dependability.

Exceptional Marine Facilities.

Western Marine Department

209 W. Jackson Boulevard

Chicago, Ill.

Vessel	Fleet No.	Vessel	Fleet No.
Aurelia	418	Bell, Sir I. L.....	300
Aurora	76	Bellechasse	248
Austin H.	160	Belleville	42
Aviso	318	Belvoir	182
Back Bay	369	Benmaple	304
Bacon, Melvin S...	98	Bennet, F. R.	221
Badger	260	Bennington	369
Badger State	141	Berryton	236
Bailey	214	Bertier	248
Bainbridge	18	Berwind, Ed. J....	273
Baird, Frank B....	24	Bess, Earl	230
Baker, George F... 300		Bessemer, Sir H... 300	
Ball Brothers	381	Bessie M.	127
Ball, Frank C. .. 381		Bethalma	159
Baltimore	26	Bethlehem	19
Barge	137	Betty D.	125
Barkhamstead	312	Bielman, C. F..... 327	
Barlum, John J... 11		Bielman, Jr., C. F. 20	
Barlum, Thomas... 11		Bienville	
Barnum, G. G..... 385		(nee McKie) 213	
Barrallton	122	Billings, Frank ... 176	
Barrie	42	Binning, J. R..... 160	
Barth, L. L. 76		Birch	407
Bartelme		Birchton	236
(nee Central		Black, Clarence A. 300	
West)	69	Black Diamond ... 146	
Batavia	212	Black Diamond ... 299	
Batchawana	89	Black, H. F. 153	
Battle, James	93	Block, Joseph	175
Baxter		Block, L. E. 175	
(see Colbert)		Block, Philip D... 176	
Baxter, Dick	260	Bluebell	360
Bayfield	12	Boardman, J. W. 174	
Bay State	82	Boeckling, G. A.... 14	
Bayton	236	Boland, John J... 23	
Bay View	55	Bos, C. J. 414	
Beaverstone	16	Bowden, W. A.... 89	
Beaverton	42	Bowers, L. M. ... 379	
Beauvais, Ernest		Bowman, A. F. 98	
E.	133	Bradley, Carl D.... 28	
Becker, W. H. 17		Bradley, Charles	
Bedell	264	H.	22
Beechbay	394	Bradley, M. A.... 32	
Belgium	144	Brailey, James E. 203	
		Brainard, Katie... 418	



Join and Save

Become a member of our Marine Savings Club and save money each pay day through your Captain.

Central-ize

Central National Bank

of Cleveland

Vessel	Fleet No.	Vessel	Fleet No.
Brandon	369	Butler, Jr., Jos. G.	176
Brant	43	Buttercup	122
Brazil	177	Butterfield	263
Brentwood	42	Byers, A. M.	329
Bricoldoc	282	C.	363
Brightie	22	C. A. B.	149
Brighton	42	Cadillac	67
Brighton	326	Cadillac	92
Brignogan	42	Cadwell, C. W.	277
Britannia	92	Cahill, James F... ..	337
Brittanic	252	Cahill, Walter	141
Briton	34	Calcite	28
Britt (nee G. N. Wilson)	412	Caldera	256
Britt, Thomas	413	Calgadoc	282
Britten, Fred A... ..	83	Calgarian	42
Brockton	369	California	145
Brockville	197	Calkins, Bertie	224
Bronson, H. F.	98	Callender, D. E... ..	413
Brookton	236	Calumet	141
Brower, Henry F. ..	148	Calumet	295
Brown Brothers ..	164	Calverley, Jr., W. D.	176
Brown, Fayette	32	Cambria	19
Brown, Harvey H. ..	32	Campbell, J. A... ..	295
Brown, J. J. H.	30	Camrose	42
Brulin	320	Canadian	42
Bruxelles	230	Canadiana	35
Bryn Mawr	300	Canadian Gunner (see Canatco)	
B. S. L. No. 1... ..	230	Canadian Harvester (see Dalwarnic)	
Buckley, Ed.	287	Canadoc	282
Budd, Ralph	146	Canatco (nee Canadian Gunner)	41
Buffalo	145	Canmore	42
Buffalonian	78	Canopus	295
Buffington, E. J. ..	300	Cape Diamond	42
Bug	107	Cape Eternity	42
Bunce, E. M. (nee Mountfacon)	244	Cape Trinity	42
Bunsen, R. W. E. ..	300	Caribou	99
Burger	118	Carl	349
Burgess, Rose	124		
Burlington	369		
Burma	355		
Butler, Bessie	89		

Preservo

Copyrighted U.S. and Canada Patent Offices

the only reliable
weatherproofing and
preservative for canvas

DOUBLES THE WEAR OF YOUR
CANVAS

WATERPROOFS YOUR CANVAS

MILDEWPROOFS YOUR CANVAS

Insist on getting the best—
“PRESERVO”

Robeson Preservo Company

Sole Manufacturers

Port Huron, Mich.

Canadian Branch: Sarnia, Ontario.

The Upson Walton Company,
Cleveland, Ohio

Geo. B. Carpenter Company, Chicago, Ill.

Connelly Bros., Buffalo, N. Y.

Jerry McCarthy, Buffalo, N. Y.

Joys Bros., Milwaukee, Wis.

Vessel	Fleet No.	Vessel	Fleet No.
Carlotta	78	Chipman, Susie	56
Carney, Fred	75	Chippewa	42
Carolina	136	Chippewa	176
Cartierdoc	282	Chippewa	344
Carrington, M. D.	422	Chisholm, Jr.,	
Carroll, J. E.	36	A. S.	192
Carroll, Weston		Christie, T. S....	165
M.	36	Cincinnati	26
Casco	209	City of Bangor...	270
Case, J. I.	355	City of Benton	
Cassidy, James H.	141	Harbor	136
Cataract	42	City of Buffalo ...	65
Cayuga	22	City of Cleveland	
Cayuga	42	III	90
Cedarbay	395	City of Detroit III	90
Cedarton	236	City of Dover	130
Central	241	City of Erie	65
Central West		City of Grand	
(see Bartelme)		Haven	366
Cetus		City of Grand	
(nee S. H.)		Rapids	136
Squire	295	City of Hamilton..	42
Chamberlain,		City of Holland...	136
C. W.	75	City of Kingston..	42
Chambers, Edward		City of Montreal..	42
(nee North Sea)	146	City of Ottawa...	42
Champion	376	City of Port	
Champlain	98	Huron	307
Chandler	42	City of St. Ignace	66
Chapleau	42	City of St. Joseph	136
Charles, Dick	260	City of Sarnia	307
Charles L.	200	City of Saugatuck	136
Charlotte	173	City of Toronto ...	42
Chattanooga	26	City of Walker-	
Chatsworth	42	ville	42
Chelsea	44	City of Windsor..	42
Chemong	53	Claremont	250
Chicago	55	Clark Brothers	359
Chicago	146	Clark, Simon	107
Chicago Tribune..	60	Clark, E. A. S...	295
Chicora	264	Clarkson, Worrell..	365
Chief	6	Clement, Norman	
Chief Wawatam ..	225	P.	24
Chieftain	85	Clement, Stephen	
Chinook	185	M.	23

WIRE ROPE

for

Snubbing and Unloading

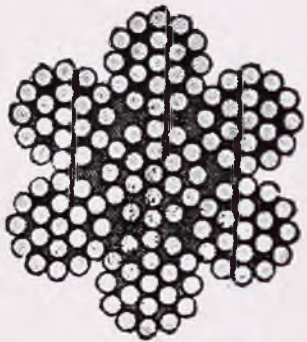

Solid Centre Ropes
for Compressors
and Snubbing



6 strands 24 wires
for Mooring Lines

All Ropes Delivered At
Any Port In Ontario or
Quebec. Freight Paid.

Stock carried at Hamilton and
Montreal

Manufactured by

**THE
B. GREENING WIRE CO.
Limited**

Hamilton, Ont.

Montreal, Que.

Vessel	Fleet No.	Vessel	Fleet No.
Clemson, D. M....	300	Cooke, Delos W...	146
Clinton	192	Coolidge, S. B.....	176
Clover	408	Coralia	270
Clyde, The	424	Cordova	95
Coalhurst	43	Corey, William E.	300
Cobalt	75	Corliss, George H.	300
Cobourg	102	Cornelius, Adam	
Coddington, Ross..	78	E.	23
Colbert		Cornell	300
(nee Baxter) ..	213	Corning, Ida	
Cole, Thomas F...	300	Cornwall	103
Colin W.	340	Corona	42
Collier	246	Corona	
Collier, No. 1.....	42	(see Freedom)	
Collingwood	42	Cort, Henry	207
Collins, E. C.	300	Corvus	295
Colomb	213	Coteau	98
Colonel	68	Cotoco	78
Colorado	145	Cotton, Nellie	86
Colpet	337	Cottonwood	85
Columbia	92	Coulby, Harry	295
Columbia	189	Coulee	378
Columbia	370	Courtney L.....	26
Columbia	420	Courtright	42
Columbus, Chris-		Covalt	255
topher	136	Cowan, W. P.	363
Commerce	105	Cowle, John B....	144
Commerce	240	Cowles, Benj. L.	78
Commodore	210	Cowles, Lotta L...	78
Compton	355	S. T. Crapo	174
Concretia	248	Crawford, George	
Conmee, A. B.	338	G.	300
Conneaut	432	Crawford, W. D...	158
Connecticut	145	Craycroft	
Connell, Charles		(see Green, Fred	
J.	120	W.)	
Connelly Bros.		Crescent	36
No. 1	74	Crescent	78
Connelly Bros.		Crete	140
No. 2	74	Crete	295
Conners, W. J.	146	Crocus	407
Conqueror	355	Croft, Harry W...	32
Constitution	312	Crosby, E. G.....	429
Constitution	326	Crosby, W. J.....	190
Cook, Robert H...	204	Crowley, P. E.....	146

The Improved
FILTRATOR
 WATER COOLED
 gives
 permanently clean boilers

NON
CHEMICAL
PROCESS
OF
TREATING
BOILERS

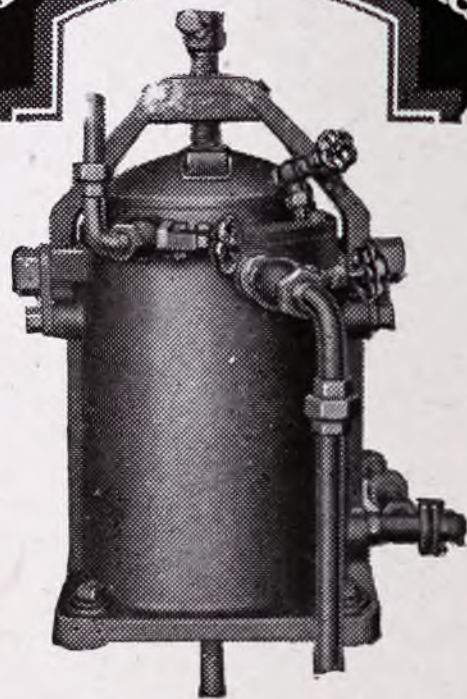

ELIMINATES
CORROSION
PITTING
SCALE
OIL

Several thousand successful installations.

Agent for Great Lakes

W. G. Bartenfeld
 348 Rockefeller Bldg. Cleveland, Ohio
 Telephone Main 4768

FILTRATORS COMPANY
 96 Liberty St. New York

FILTRATORS

Vessel	Fleet No.	Vessel	Fleet No.
Cullen, John W...	222	Dispatch	33
Cumberland	405	Dixson, G. D.....	146
Curlew	142	Dobbins, D. P.....	302
Cyclone	390	Dolphin	278
Cygnus	295	Donaldson, J. A....	17
Dahlke, H.	406	Donnacona	42
Daisy	418	Donnelly	102
Dalhousie City ...	267	Donnelly, Charles	146
Dalton, Henry G...	295	Donner, W. H....	156
Dalwarnic		Donovan, George	
(nee Canadian		R.	391
Harvester)	41	Dorothea D.	256
Dana, Major	424	Dorothy	204
Daniels, Wm. H...	24	Douglass, E. C....	24
Dark, Samuel J...	336	Dover	
Davidson	162	(nee Frank E.	
Davidson, James..	381	Kirby)	268
Davidson, James		DoVille, R. E.....	105
E.	382	Driscoll, J. H.....	253
Davidson, Louis		Drumahoe	53
R.	23	Dudley, Joe	142
Davidson, Thomas	270	Duluth	146
Davie, George T.	361	Dundas	42
Davis, J. M.....	146	Dunkirk	145
Davis, Lyman	84	Dunmore	355
Davis, Wm.	126	Dunn, Jr., John...	144
Davock, W. B....	295	Dunn, Stuart H...	337
Dayton	38	Dupre	305
Defender	204	Dupre, Andree ...	355
De Grasse	341	Dupre, Jr., Yvon	355
Delaware	145	Durston, J. F.....	144
Delaware		Dussault, D.	303
(see F. W. Sargent)		Dyment N.	50
Delver	305	Eads, James B....	301
Dempsey, E. C....	141	Eagle	77
Denby, Edwin ...	370	Earl A.	133
Denmark	144	Eastern States ...	90
Destroyer	370	Easton	236
Detector	248	Ecorse	143
De Tour	111	Edenborn, William	30
Detroit	145	Edmonton	42
Detroit	415	Edna G.	106
Dickson, Wm. B...	300	Edward, George...	323
Dinkey, Alva C...	300	Edward, James ...	141



"THE FILM OF PROTECTION FOR BOILERS"

25 Years' MARINE experience proves conclusively "Magic" prevents scale formation, removes old scale gradually, stops corrosion, pitting and minor leaks, and will not cause your boilers to foam.

Stocks carried in following Ports:

- Connelly Bros., Buffalo, N. Y.
- J. & A. Thomson, Cleveland, O.
- Edgar's Sugar Warehouse,
Detroit, Mich.
- Joy Bros., Milwaukee, Wis.
- McDougall Terminal Warehouse,
Duluth, Minn.

GARRATT-CALLAHAN CO.
310 So. Michigan Ave., Chicago

MAGIC BOILER PRESERVATIVE

Vessel	Fleet No.	Vessel	Fleet No.
Edward K.	238	Favorite	145
Edwards, J. R.	42	Fayling	433
Effie L.	141	Felicia	355
Elba	295	Fellowcraft	270
Eleanor	325	Ferbert, A. H.....	300
Elert	126	Ferdinand	310
Elgin	42	Ferris, Charley	12
Ellen V.....	256	Ferris, James E... 176	
Elliott, James R... 93		Ferro	45
Elmbay	396	Field, Albert C... 24	
Elmira	186	Field, William A. 145	
Elsa M.	5	Field, William K... 329	
Elva	9	Filbert, William J. 300	
Elwood, Isaac L. 300		Fillmore, Clarence	
Emba	246	J.	123
Emerson, George.. 210		Finland	144
Emerson, W. J.... 373		Fisher, Thomas ... 142	
Emery, John R... 114		Fitch, William F. 184	
Emilia	248	Fitzgerald, Rich-	
Emperor	42	ard	192
Empire	98	Fitzgerald, R. P. 115	
Empress	161	Fitzgerald, W. E. 367	
En-ar-co	45	Fix, Clarence	121
Erie	312	Florence	117
Erie		Florence	278
(nee Owana) 268		Florida	145
Erna	263	Florida	420
Escort	160	Fontana	71
Essex	416	Foote, James B... 391	
Ethel	159	Ford, Benson	122
Ethel	160	Ford, Emory L... 273	
Eugene	349	Ford II, Henry..... 122	
Eureka	355	Fort Ann	204
Ewig, Harry T.... 411		Fort Edward	204
		Fort Meigs	345
Fairbairn, Sir		Fortwildoc	282
Wm.	300	Foster, Parks	311
Fairmount	42	Fox, William G.... 78	
Fairport	145	Francomb, J. A... 38	
Falcon	295	Frank W.	145
Falken	224	Franklin	121
Farley, J. C. 62		Franklin	239
Farr, M. E. 387		Franz, W. C. 3	
Farrell, James A. 300		Frantz, Joseph H... 193	
Fashion	232	Fraser, Annette... 124	

Wakefield Boiler Compound

(Patented)

*Used successfully by 250 Steamers
Kept in stock by the following firms.*

- Duluth Marine Supply Co.
Duluth, Minn.
- Indiana Harbor Marine Supply Co.
Indiana Harbor, Ind.
- Hardy & Dischinger Toledo, O.
- P. A. Sperry Huron, O.
- Lorain Hardware Co. Lorain, O.
- The McKinnon Iron Works Co.
Ashtabula, O.
- The Rud Machine Co. Cleveland, O.
- A. H. Brebner Erie, Pa.
- H. S. Wright Buffalo, N. Y.
- E. E. Lawrence Jr. Fairport Harbor, O.
- Saefke & Nienow Co.,
Milwaukee, Wis.
- G. E. Brading, 3221 E. 92nd St.,
Chicago, Ill.
- Pittsburgh S. S. Co. Conneaut, O.

Wakefield Boiler Compound Co., Inc.

Factory and Office
667-669 Oakwood Avenue
East Aurora, N. Y.

Vessel	Fleet No.	Vessel	Fleet No.
Fraser, Jean	124	Gleneagles	42
Fredmac	355	Glenelg	42
Freedom		Glen Erie	256
(nee Corona)	76	Glenmount	42
Freyer, Robert L.	170	Glenross	42
Frick, Henry C...	300	Glenn	121
Fritz, John	300	Glide	260
Frontenac	67	Goderich	42
Frontenac	102	Godfrey, Jeremiah	42
Frontenac	376	Good Time	65
Frontier	300	Goodwin, Joe	160
Fulton, Robert ...	300	Goodyear, F. H....	23
Fundy	305	Gorman, J. E.	146
		Goulder, H. D.....	193
Gallagher, Michael	17	Grace B.	2
Garden City	330	Grammer, G. J....	25
Gargantua	210	Grampian	22
Garretson, General	426	Granby	42
Gary	145	Grand Haven	138
Gary, Elbert H....	300	Grand Island	67
Gates, John W....	300	Grandon	309
Gawn, Thomas ...	135	Grand Rapids	138
Geary, G. R.	388	Grant, F. W.	43
Geer, Linford E....	329	Grattan, W. S....	87
Gehm, John	272	Gray, G. R.	210
General	111	Great Western ...	117
Genoa	185	Greater Buffalo ..	90
Georger, F. A. ...	167	Greater Detroit ...	90
Georgia	145	Green, Andrew H.	141
Georgia	429	Green, C. H.....	295
German, A. M....	32	Green, Fred W.	
Gibson, A. E.....	96	(nee Craycroft)	333
Gifford	241	Green River	98
Gilbert	208	Greiling, Fred C...	147
Gilbert	302	Grenville	248
Gill, Alice M. ...	192	Greyhound	322
Gillen, Edward E.	133	Griffin	430
Gillen, M. J.	110	Guardian	312
Gilmore, Q. A. ..	145	Gwa-Goli	237
Gladiator	109		
Gladiator	370	Hackett, M. E....	149
Gladys H.	75	Hagarty	42
Glen Allen	13	Haggart, John ...	279
Glenbogie	301	Halcyon	416
Glenda	349	Hall	278

CLEAN BOILERS

RED STAR**MARINE EXTRACT***Standard For More Than 25 Years*

Exclusive Agents for Great Lakes

THE THOMPSON-HAYES CO.

821-3 Rockefeller Bldg. Cleveland, O.

TEL. MAIN 0320

Stocks Carried at Following Ports:

Indiana Harbor Marine Supply Co.
Indiana Harbor, Ind.
McKinnon Iron Works Co.
Ashtabula Harbor, Ohio
The R. & R. Marine Supply Co.
Ashtabula Harbor, Ohio
J. F. Regan, 10 Erie Avenue, Lorain, O.
Hardy & Dischinger Co., Toledo, O.
A. H. Brebner, Erie, Pa.
Geo. A. Naegele, Huron, O.
The Upson-Walton Co.,
1310 W. 11th St., Cleveland, O.
J. & A. Thomson, 1232 W. 11th St.
Cleveland, O.
Pittsburgh Steamship Co.,
Conneaut Store, Conneaut, O.
Interlake Steamship Co.,
Store, Buffalo, N. Y.
South Chicago Marine Supply Co.,
Chicago, Ill.
E. E. Lawrence & Son,
Fairport Harbor, O.

Factory and Home Office

LAKE ERIE MANFG. CO., Inc.
192-198 CHICAGO ST. BUFFALO, N. Y.

Vessel	Fleet No.	Vessel	Fleet No.
Hall, Jessie	79	Heiden, Charles ..	406
Hall, Mary P.	102	Helen S.	137
Halladay	221	Helm, D. T.	258
Hallan Bros.	107	Hemlock	295
Halsted	356	Hercules	88
Hamildoc	282	Hercules	370
Hamilton	42	Hiawatha	306
Hamonic	42	Hibou	
Handy Boy	185	(nee Alice)	100
Hanlan, John	359	Hilda	418
Hanna, D. B.	391	Hill, James J.	300
Hanna, Jr., H. M.	193	Hill, L. W.	157
Hanna, L. C.	156	Hinckley	167
Harding, Abner C.	145	Hobson, Robert ...	295
Harlow	134	Holcomb, R. T. ...	168
Harriett D.	101	Holland, N. C. ...	22
Harrison	162	Holley, Alexander	292
Harrison, Carter		Hollis M.	26
H.	334	Holloway, J. A. ..	24
Harrow, W. G.	338	Home Smith	3
Hart, Frank W.	383	Homer	
Hart, Judge	24	(see Lakegravel)	
Hartwell, Fred G.	273	Hoover & Mason..	387
Harvard	145	Houghten, Henry...	351
Harvard	300	Houghton, Douglas	300
Harvester, The ...	180	House, Francis E.	300
Harvey	374	Hoyt, Elton, II...	32
Harvey, A. F.	300	Hubbard, Charles	144
Harvey, F. E.	406	Hubbard, C. R.	193
Hassayampa	141	Hudson	355
Hastings	42	Huguenot	42
Hatfield, Joshua		Humphrey, George	
A.	300	M.	365
Hausler, Jr., Mar-		Humrick	122
tin	141	Huntley, Charles	
Hausler, M. G. ..	40	R.	24
Haynes, F. J.	15	Huron	139
Hazard, William		Huron	145
A.	428	Huron	406
Hazel	61	Huron	432
Hebard, Charles		Huronic	42
S.	426	Hustler	269
Hebard, D.	122	Hutchinson, C. L.	176
Hector	34	Hutchinson, J. M.	51
Hector	355	Hutt, Hattie	274

GARLOCK
TRADE MARK

Garlock Marine Metal Packing

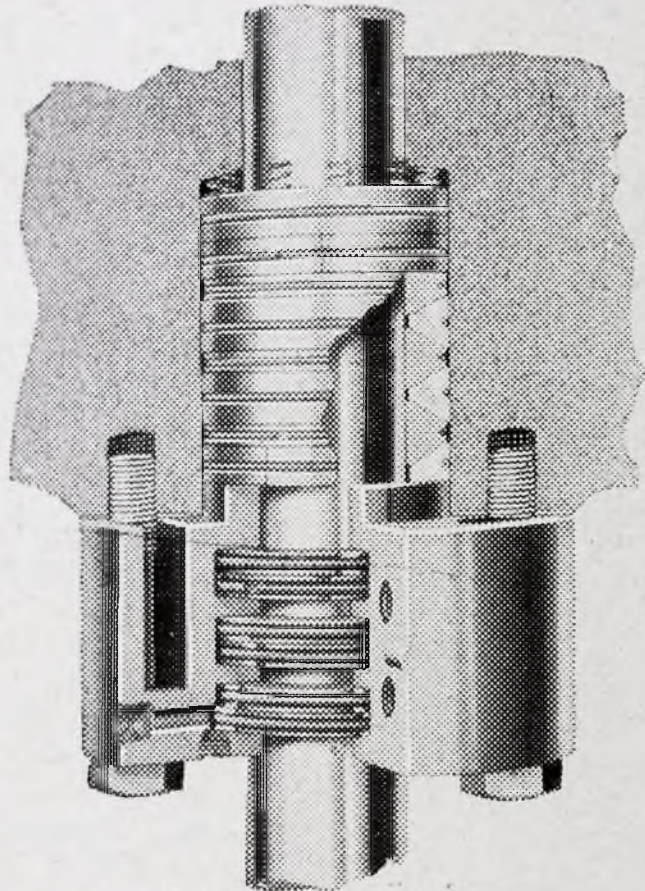

Garlock 805-870 Combination Metal Packing is especially recommended for service on High or Low Pressure Piston Rods of all types of Vertical Marine Engines. We know of installations that have been in service fifteen years and are still giving complete satisfaction.

Write to the nearest branch sales office for descriptive folder and specification blank.

THE GARLOCK PACKING COMPANY
Great Lakes Sales Offices
Chicago, Ill. Detroit, Mich. Cleveland, O.
Milwaukee, Wis.
Hamilton, Toronto, Ont. Montreal, Que.

The Standard Packing of the World

Vessel	Fleet No.	Vessel	Fleet No.
Hyacinth	409	Jenkins, Charles	
Hydro	192	O.	184
Hyman	36	Jenney, W. Le	
		Baron	300
Ignifer	42	John, J. R.	294
Illinois	59	John, Jr.	431
Illinois	136	Johnston, Robert	
Illinois	145	E.	76
Imperoyal	179	Johnston, William	102
India	321	Jones, B. F.	183
India	351	Jones, Harry R. ..	295
Indiana	136	Josephine	83
Indiana	145	Juniata	146
Industry	240	Jupiter	194
Ingalls, George H.	25	Jupiter	295
Inland	25	Jupiter	370
Inland	31		
Interlaken	333	Kalkaska	222
International	290	Kamloops	42
Interstate	419	Kansas	145
Iocolite	179	Kearsarge	41
I. O. Ltd. No. 6	179	Keenan	188
Iowa	145	Kellers, Frederick	
Ireland	75	T.	241
Ireland, R. L. ...	198	Kelley Island	192
Iron Cliff	185	Kelley, Norman ..	192
Iroquois	57	Kendall, Harvey	
Island Queen	360	J.	150
Isabella H.	167	Kenefick, Judge...	24
Isabelle	200	Kennedy, Hugh ..	23
Iselin, Adrian	150	Kennedy, John	
Ishpeming	67	McCartney	411
Islander	9	Kenora	42
Islay	107	Kenosha	145
Islet Prince	373	Kenosha	421
		Kerr, D. G.	300
Jack	249	Keuka	186
Jackson, G. K. ...	287	Keewatin	47
Jacob, C. W.....	151	Keybar	195
Jaffray, C. T. ...	146	Keybell	195
Jamaica	264	Keynor	195
Jamaica	317	Keyport	195
Jasmine	360	Keystate	195
Jeannette P.	280	Keyvive	195
Jeannette, R.	355	Keywest	195



THE IDEAL METALLIC PACKING

NEVER WEARS OUT

Holds the highest pressure, the highest temperature and the highest speed used in any engine room.

For Steam, Oil, Compressed Air, Ammonia, Tar, Water Brine, Acid, Gas, Paint, etc. Write for sample set—enough to pack one small rod or valve stem—charges prepaid.

Cassco "Special for Superheat" holds 1000 degrees Fahrenheit.

CASSCO BAR-METALLIC PACKING CO.

3559 Lincoln Ave., Cor. Addison Street CHICAGO
Phone 9164 Lake View

Vessel	Fleet No.	Vessel	Fleet No.
Kildonan	355	Laketon	236
Kinch, William H.	141	Lakewood	36
Kindersley	42	Lanark	42
King	249	Landsdowne	139
King, A. B.	22	Langell Boys	52
King, Erl	196	Langell, Simon ...	245
King, Willis L.....	183	Lapwing	355
Kingdoc	282	La Salle	75
Kingman	36	La Salle	92
Kingston	42	La Salle	120
Kingston	355	Laughlin, James..	183
Kinmount	42	Laurette	230
Kinney, A. T. ...	198	Lauzon	213
Kiowa	22	Lavaldoc	282
Kirby, Frank E.		Laviolette, G. F.	
(see Dover)		(see Peter)	
Kling, John A. ...	331	Lawrence	307
Knight Templar...	133	Lebanon	19
Koenig, Peter ...	199	Lee	141
Koerber, Jr.,		Lehigh	19
Henry	121	Lemoyne	42
Knowlton	42	Lenahan, Ed.....	78
Kopp, Jacob T....	23	Lenahan, John J.	
Krapp, W. D. . .	121	(nee Oswegatchie)	78
Kreetan	201	Lennox	42
Krupp, Alfred ...	300	Leonard, George	
		B.	144
La Belle	155	Leopold, N. F.....	175
Lachinedoc	282	Le Progress	64
Lackawanna	19	Leslie, Alexander	
Lady Grey	248	(nee H. A. Rock)	205
Lagonda	295	Lethbridge	42
Lahman, Sr.,		Lewiston	72
W. F.	6	Levis	310
Lake Allen	122	Liberty	27
Lake Crystal	122	Liberty	76
Lake George	85	Liberty	78
Lakegravel		Lillian A.	1
(nee Homer) ...	260	Limit, The	424
Lake Hemlock ...	122	Lindabury, Rich-	
Lake Kytte	122	ard V.....	300
Lake Louise	122	Linn, William R....	300
Lake Michigan ...	302	Lingeman, O. J...	244
Lakeport	36		
Lakeside III	33		

ANCHOR
Security Wedge Packing
Style 800

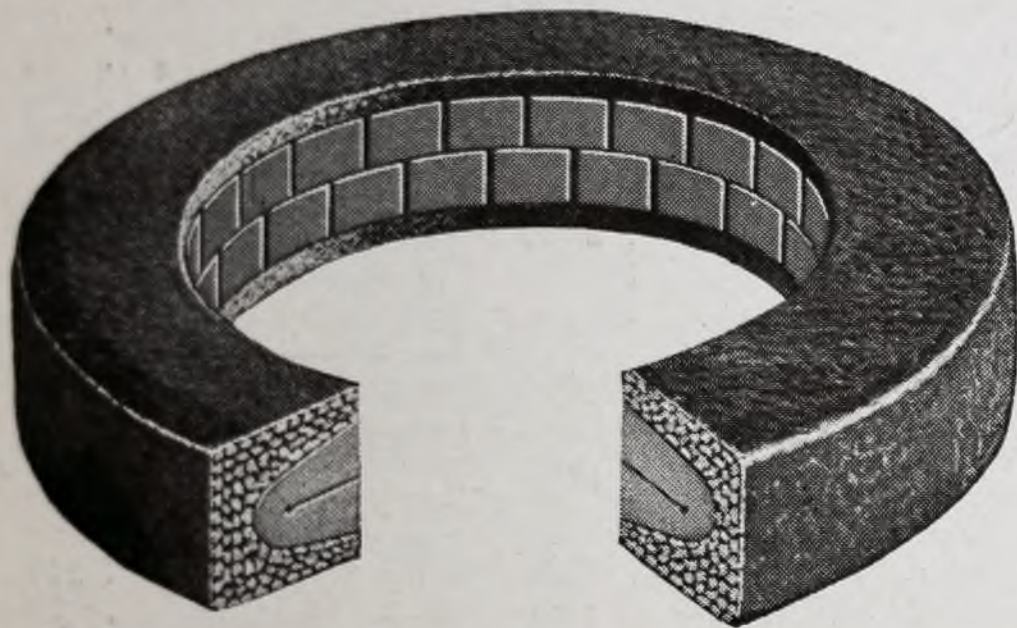

CONSTRUCTION—Security Wedge Packing is a combination of a metal core and an asbestos fabric casing, designed on scientific principles, which insure the following advantages:

The metal core is concentrated on the wearing surface and forms a continuity of metal in contact with the rod. The metal being non-frictional and flexible, conforms readily to the curve of the rod, when the Rings are placed in the stuffing box, providing free rod action with low frictional losses.

In use, the glands, when tightened, force the metal wedge shape core slightly beyond the face of the asbestos casing on to the rod.

As only the metal core is in contact with the rod, the rod is polished and cannot be scored. The construction assures great durability, and will withstand high temperatures.

The asbestos fabric casing acts as a steam seal, preventing the escape of steam or liquid through the stuffing box. It is also a cushion for the metal core, and provides proper amount of elasticity.

The Anchor Packing Company

Home Office: Philadelphia, Pa.

Great Lakes Sales Offices:

Cleveland, O.
 Chicago, Ill.

Buffalo, N.Y.
 Detroit, Mich.

Vessel	Fleet No.	Vessel	Fleet No.
Livingston	236	Macassa	42
Livingstone, Wil-		MacAuley, Laird..	43
liam	193	Macbeth, A. D.....	34
Lloyd, C. C.	256	MacKay, Robert....	159
Logie, John	256	Mackinaw City ...	242
Loomis, Ed. E. ..	146	MacNaughton,	
Longueuil	42	James	426
Lorain	145	MacPherson,	
Loretta	89	N. B.	24
Lotus	49	Macsin	355
Lotus		Madison	138
(nee Strohn) ...	375	Maggie L.	239
Louise	200	Magna	300
Louisiana	145	Mago, B. A.	227
Louisville	26	Magog	42
Lucknow	37	Mago Transit No.	
Luckport	37	I	227
Luebke	216	Mago Transit No.	
Luella	360	II	227
Lusk, Col.	128	Maia	300
Lutz, T. C.....	1	Maida	312
Lydon, William A.	141	Maid of the Mist	
Lynch, Conn.....	43	No. 1	228
Lynch, Thomas ..	300	Maid of the Mist	
Lyon, Charles	46	No. 2	228
McCullough, C. H.	295	Maine	145
McDougall, Alex..	300	Maitland No. 1... 389	
McFarland		Maitland Rose ... 256	
(nee Reeb)	412	Maitland, Thomas 313	
McGean, W. H....	176	Maley, George W. 229	
McGonagle, Wil-		Malietoa	300
liam A.	108	Malton	236
McGonagle, Wil-		Mamie	102
liam A.	300	Manda	300
McIntosh, H. P... 426		Manila	300
McKay, Robert ... 159		Manistique	325
McKeon, J.....	21	Manitoba	47
McKerchey, J. M... 192		Manitou	99
McKie		Manitou	243
(see Bienville)		Manitoulin	279
McKinney, Price... 176		Manitowoc	405
McLauchlan, Wm. 295		Manitowoc	415
McLean, John J. 300		J. P. Manning	
McLean, No. 4... 221		(see B. E.	
		West)	

VULCABESTON



Vulcabeston Sheet Packing is noted for the long service it gives. This durability applies to practically every purpose for which sheet packing is used on board a ship. In fact, Vulcabeston Sheet Packing is the only sheet packing you need to carry for hot or cold, fresh or salt water; superheated or saturated steam, ammonia and air. Write us for test samples to try out on your own ship.

Stock Carried By

H. W. McKinley Co.,	Cleveland
Multiplex Pkg. & Rubber Co.,	Toledo
Seehausen, Wehrs & Co.,	Chicago
Kenneth Anderson Co.,	Detroit
Curtis Supply Co., Inc.,	Buffalo.

A SEA-GOIN' PACKING THAT SHIPS FOR THE LIFE OF THE SHIP

SPECIFY 'VULCABESTON' EXTREME STYLE 601

Manufactured Only By

COLT'S PATENT FIREARMS MFG. CO.

Hartford, Conn., U. S. A.

Vessel	Fleet No.	Vessel	Fleet No.
Manomet	55	Mather, William	
Manon	317	G.	67
Mantadoc	282	Mathewston	236
Manuel, John S....	176	Mathilda	355
Maplebay	397	Mathiott, E. G....	411
Maplebranch	340	Mattich, Walter	
Maplecourt	42	F. (see James	
Mapleglen	42	E. Murray)	
Maplegorge	42	Mattison, C. A. ..	238
Maplegrange	42	Maunaloa	300
Maplegreen	42	Maxwell, E. G. ..	424
Mapleheath	42	Mayer, Oscar F. ..	141
Maplehill	42	Mayflower	360
Mapleton	42	Mayflower, Jr.	425
Marcia	230	Maytham, Thomas	129
Maricopa	300	Mazeppa	359
Marigold	408	M. C. K.	2
Marine	232	Meade	405
Marinette	405	Meade, J. C.	122
Marion	141	Meaford	42
Mariposa	300	Medill, Joseph	59
Maritana	300	Meldrum, H. A. ..	141
Marjorie	232	Melrose	355
Marold II	166	Menodora	43
Marquette	67	Menominee	355
Marquette & Bes-		Mercereau, W. L.	145
semer No. 1....	206	Mercier	317
Marquette & Bes-		Merrill, Julia B...	284
semer No. 2....	234	Meyer, John E....	12
Marsala	300	M. F. D. No. 15	119
Martha	300	M. F. D. No. 17	119
Martha C.	141	M. F. D. No. 19	119
Martian	42	Michigan	67
Martin, James T...	55	Michigan	145
Mary C.	141	Michigan 3rd	134
Mary Ethel	254	Midland City	130
Mary H.	172	Midland King	42
Maryland	19	Midland Prince ...	42
Maryland	145	Miller, Leonard B.	193
Marysville	223	Miller, Jr., Thos...	169
Marysville	351	Mills, D. O.....	295
Massachusetts	145	Milwaukee	138
Mataafa	300	Milwaukee	146
Mather, Samuel ..	295	Milwaukee	405
		Minch, Anna C...	259

WM. M. SAEFKE
Phone Lakeside 1205

AL NIENOW
Phone Lakeside 4652-R

OFFICE PHONE GRAND 3488

SAEFKE & NIENOW

ENGINEERS SUPPLIES

MARINE SUPPLIES OF ALL KINDS

Pipes, Valves, and Fittings

Packings of All Kinds

Machine Shop in
Connection

222 Fourth Street

MILWAUKEE, WIS.

Vessel	Fleet No.	Vessel	Fleet No.
Minch, Philip	365	Murray, James J. (nee Walter F. Mattich)	141
Minch, Sophia	302	Muscallonge	355
Mingoe	22	Muskoka	75
Minitaga	418	Myer, W. H.	247
Minnesota	145	Myra	355
Minnie W.	142	Mystic	433
Missisquoi	104		
Mississippi	145	Nadine	418
Missouri	54	Nashville	26
Missouri	145	Nasmyth, James... 300	
Missouri	429	Nassau	178
Mitchell, Pente- cost	300	Nathalie R.	163
Mitchell, Samuel... 174		National	388
Mitschibre	95	Navagh, Jos.	109
Moll, Clifford F... 23		Neff, Mary K.	261
Mondoc	282	Neff, Sidney, O.... 223	
Monitor	341	Negaunee	67
Montauk	73	Neilson, James B. (see J. T. Reid)	
Montezuma	85	Nelson (nee Panay)	69
Mountfaucon (see B. M. Bunca)		Neptune	295
Montreal	418	Nessen, N. J.	373
Morgan, Arthur ..	355	Nettleton, A. E. ..	144
Morgan, Gerald	355	Nevada	289
Morgan, J. Pier- pont	300	Newbrundoc	282
Morgan, Jr., J. P. 300		New Dominion	217
Morrell, Daniel J. 39		New Jersey	145
Morrison, J. D.	142	Newman, T. F....	145
Morrow, Joe S. ..	235	Newton	264
Morse, Jay C.....	295	New York	26
Morse, Sam F. B. 295		New York	145
Mueller	170	New York News..	60
Mullen, John	257	Niagara	131
Mullen, Martin... 176		Niagara	140
Munising	67	Nightingale	147
Munson, John G... 28		Nipigon	373
Murphy, Alice (nee Walnero No. 2)....	78	Nisbet, W. F.....	24
Murphy, Denis	278	Nitchie	276
Murphy, Simon J. 300		Norfolk	42
Murray, Alfred J. 214		Noronic	42
		North American..	58
		North Harbor	145

Valves of Lasting Service

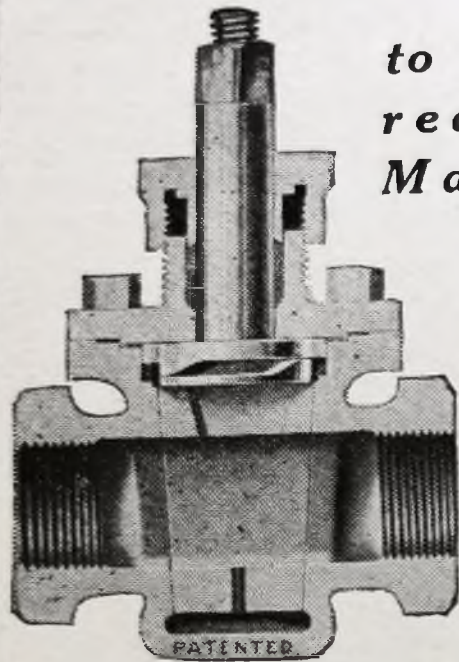

to meet the exacting requirements of Marine Standards.

HOMESTEAD Quarter Turn VALVES

Straightway, Three-way and Four-way types.

Hoivalco-Homestead Combination Boiler Blow-off Valves for Marine Boilers

Agents in all ports:

M. S. Maleson, 903 Rockefeller Bldg.,
Cleveland, Ohio

F. A. Herr Company, 360 Warwick Ave.,
Buffalo, N. Y.

Kenneth Anderson Co., 133 E. Atwater St.,
Detroit, Mich.

O. C. Keckley Co., 565 Washington Blvd.,
Chicago, Ill.

W. P. & R. S. Mars, 412 W. First St., Duluth, Minn.
Standard Sanitary Mfg. Co., 1002 Summit St.,
Toledo, Ohio

A catalog will be sent on request

HOMESTEAD VALVE MFG. CO.

Homestead, Pa.

Vessel	Fleet No.	Vessel	Fleet No.
North Sea (see Edward Chambers)		Ontario No. 2.....	275
North Star	146	Oregon	145
Northton	236	Oriana	256
Northumberland ..	266	Orleans	264
Norton, David Z..	193	Orr, Arthur	41
Norway	144	Orton, Minnie E...	42
Nottingham, Wm...	144	Osborn, F. C.....	406
Novadoc	282	Osborne, A. W....	426
Number 1	390	Osler	42
Number 1. Q. & R.	88	Oswegatchie (see John J. Lenahan)	
Number 2	221	Otis, John	185
No. 2	390	Ottawa	67
Number 3	221	Ottawan	278
Number 3	424	Outadoc	282
Number 4	424	Our Son	346
Number 15	119	Outagamie	363
Number 17	119	Owana (see Erie)	
Number 29	119	Owen	6
Number 56	409	Oxford	42
Number 75	408		
Number 77	409	F. W. D. No. 109	88
Number 82	409	P. W. D. No. 117	88
Number 89	409	Page, M. W.	22
Number 95	409	Pahlow, Louis ...	218
Number 96	408	Paine, William A.	176
Number 98	409	Paisley, Robert J.	69
Number 99	408	Palmer, Wm. P...	23
Number 103	409	Palmer, Wm. P...	300
Number 137	301	Panay (see Nelson)	
O'Connor, Dick ..	260	Pandora	214
O'Hagan, John J.	272	Pappoose	92
Oakbay	398	Pargny, E. W.....	300
Oak Leaf	366	Parker, George W.	281
Oakton	236	Parks, O. E.	354
Oatland	42	Passepartout	159
Octorara	146	Patdoris	361
Odanah	295	Pathfinder	295
Ohio	145	Patton, George H.	63
Oiseau	285	Paul, L.	280
Olcott, William J.	300	Pearson	406
Ontadoc	282	Pearson, Jay A...	134
Ontario No. 1.....	275		

"The Standard for all Marine Installations"

BRUNSWICK-KROESCHELL REFRIGERATION

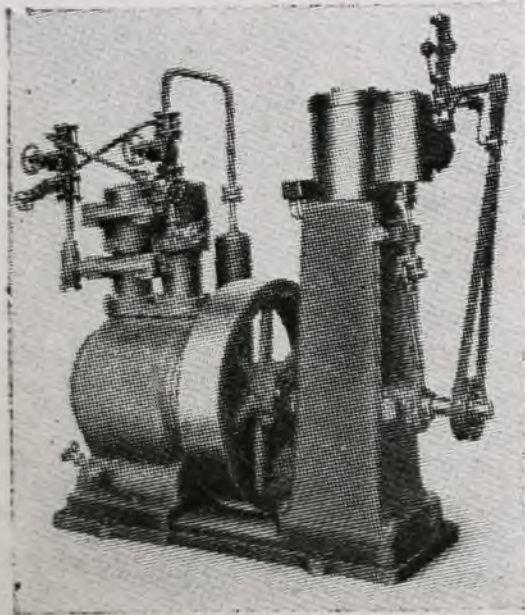

OVER TWO THOUSAND
VESSELS EQUIPPED

*Your choice of either the
Ammonia or Carbonic
Anhydride system.*

BRUNSWICK-KROESCHELL COMPANY
Refrigerating & Ice Making Machinery
NEW BRUNSWICK, N.J. - CHICAGO, ILL.

BRANCHES AGENCIES AND SERVICE IN PRINCIPAL CITIES

Vessel	Fleet No.	Vessel	Fleet No.
Peckham, W. M...	78	Pioneer	67
Pedwell, Henry.....	100	Pittsburg	299
Peel	88	Pittsburgh	26
Pegasus	295	Pleasure	92
Pelee	427	Plessis	213
Pelerin	317	Plietz, William F.	323
Pellett, James H...	192	Plow Boy	121
Penetang	42	Poe, Gen. Orlando	
Penobscot	270	M.	300
Pennsylvania	75	Pollock, W. G. ...	17
Pennsylvania	75	Pomeroy, Robt. W.	24
Pentland	167	Ponoka	42
Pere Marquette 6	233	Pontiac	67
Pere Marquette 14	290	Pontiac	92
Pere Marquette 15	290	Pontoon	145
Pere Marquette 17	290	Pope, E. C.	271
Pere Marquette 18	290	Poplarbay	400
Pere Marquette 19	290	Portsmouth	42
Pere Marquette 20	290	Potter, George R.	87
Pere Marquette 21	290	Pratt, John	355
Pere Marquette 22	290	Prentice, James H.	222
Perew, John	422	Prescott	42
Perkins, Geo. W...	300	Presque Isle	70
Perry, D. P.	9	Primrose	360
Perry, Oliver H. ..	364	Prince Ray	96
Perry, W. G.	299	Princeton	7
Perseus	295	Princeton	300
Peshtigo	22	Prindoc	282
Petcol	244	Procter, Dan.	188
Peter (nee G. F.		Progress	271
Laviolette)	349	Promise	92
Peterson, Frank J.	293	Provincial II	313
Petoskey	429	Puckasaw	210
Phelps, M. G.....	113	Puritan	243
Philadelphia	26	Purvis, E. D. M.	314
Philbin, D. M. ...	380	Put-in-Bay	10
Philips, Frank D.	333	Pythonga	44
Phillippe, Louis ..	42		
Phipps, Henry ...	300	Q. H. C. No. 2....	318
Pickands, Colonel		Quayle, Thomas ..	185
James	295	Quebec	
Pierce, E. M.	145	(see St. Anne	
Pillsbury, J. S. ...	24	de Beaupre)	
Pinebay	399	Quebec	42
Pinola	162	Quebec	337

World's Record Breaking Carriers

Col. W. P. Schoonmaker H. K. Field
W. P. Snyder, Jr. Chas. M. Schwab
James McNaughton J. H. Frantz

Are All Equipped with
Steam or Electric Driven



Uniform Cold Temperatures Dry
Atmosphere Simple Operation
Refrigeration For Meat or Vegetable
Rooms
Drinking Water Ice Making Sets

SERVICE POINTS

DETROIT **BUFFALO**
Euth Lambrecht Co. Ford Bros.
3060 Michigan Ave. 29 Illinois St.

The Phoenix Ice Machine Company

Factory and Offices:
2711 Church Ave., CLEVELAND, OHIO
137 N. Erie St., TOLEDO, OHIO

Vessel	Fleet No.	Vessel	Fleet No.
Quedoc	282	Rensselaer	300
Queen	249	Rescue	145
Queen City	300	Richard B.	338
Queen, S. A.	315	Richards, Fred E.	141
Racine	145	Richards, J. B....	24
Racine, Pierce	355	Richardson, R. R.	300
Rahane	319	Richardson, W. ...	49
Rainbow	238	Richardson, W. C.	193
Raleigh	308	Richelieu	42
Rammacher, J. J.	24	Riprap	405
Ramona	324	Riter, Charles	27
Rand, G. F.	23	Rival	355
Ranney, Rufus P.	386	Riverside	171
Rapids King	42	Riverton	236
Rapids Prince	42	Robbins 3	112
Rapids Queen	42	Robbins, F. L....	17
Ray F.	229	Robbins, S. H. ...	426
Ream, Norman B.	300	Robert E.	230
Recor, Edward P.	192	Roberts, Jr., P....	300
Record	77	Roberts, Wm. T....	23
Reddington, N. ..	355	Robinson, C. S. ...	295
Redfern, C. E. ..	211	Robinson, L. W. ..	150
Reeb (see McFarland)		Robinson, T. W. ..	28
Reed, Isabel	337	Rochester	78
Reed, James H. ...	295	Rock, H. A.	
Rees, W. D.	426	(see A. Leslie)	
Reid, J. J. (nee Jas. B. Neilson)	327	Rockefeller, Frank	55
Reidenbach, R. P.	145	Roebing, John A.	300
Reiss, Clemens A.	329	Roen, Marquis ...	333
Reiss, J. L.	329	Rogers City	241
Reiss, John P. ...	329	Rogers, G. W. ...	43
Reiss, Otto M. ...	367	Rogers, Henry H.	300
Reiss, Peter	328	Rolph, John	302
Reiss, Peter	329	Rooney, Wm. E....	97
Reiss, Richard J.	329	Roosevelt, Theo- dore	36
Reiss, William A.	329	Rosalie L.	355
Reliance	145	Rosemount	42
Reliance	210	Roumania	270
Reliance	229	Royalite	179
Relief	145	Royalton	236
Renfrew	42	Royan	42
Renown	363	Russell	44
Renvoyle	42	Russell, Gerald B.	337
		Russell, Joseph L.	337

MARINE REFRIGERATION

Since



1882

R
E
L
I
A
B
L
E

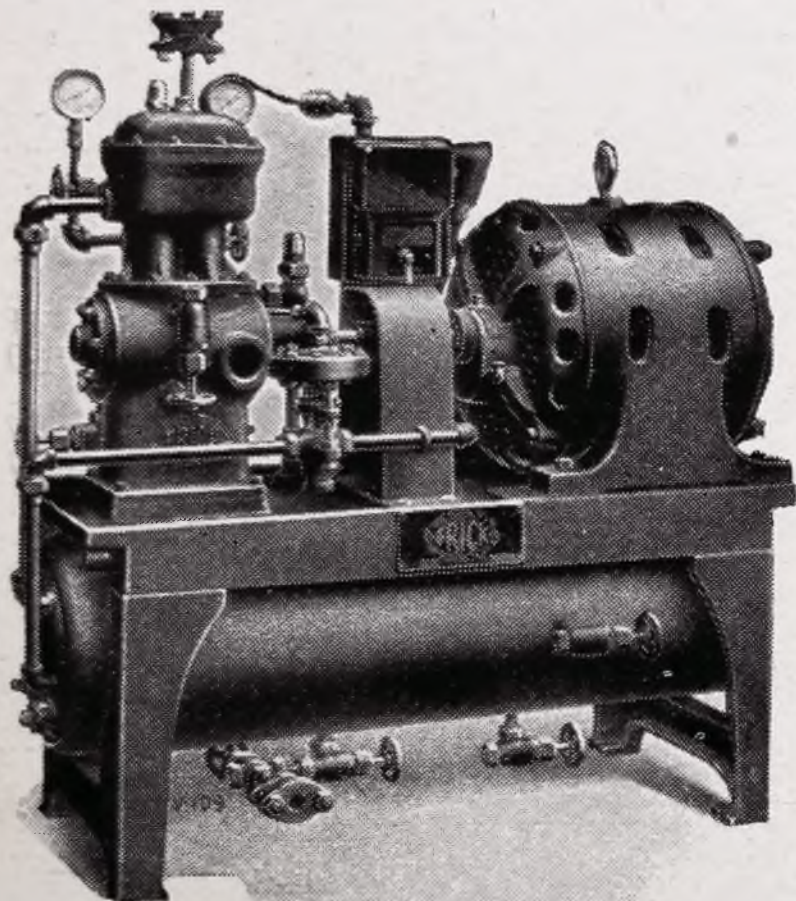

S
I
M
P
L
E
and
S
A
F
E

Sales and Service

MIDWEST ENGINEERING & EQUIPMENT CO.

617 Fulton St.

Chicago, Ill.

Vessel	Fleet No.	Vessel	Fleet No.
Sabin, L. C.	145	Selkirk	42
Sachem	110	Sellwood, Joseph ..	295
Sachem	215	Senator	68
Sacramento	85	Senneice	185a
Sagamore	312	Service	78
Saguenay	42	Shamrock	248
Sainte Ignace	242	Shaughnessy, Sir T.	18
Sainte Marie	225	Shaughraun	110
Salvage Price	315	Shaun Rhue	110
Sand Boy	315	Shaw, Howard L...	300
Sandcraft	76	Shaw, Quincy A...	152
Sandland	277	Sheadle, H. J.	67
Sandmaster	76	Sheboygan	421
Sand Merchant ...	231	Sheldon, Cora A...	185
Sands, Isabella ...	375	Shenango	353
Sandusky	145	Sherbrooke	42
Sappho	92	Sherman, W. A. ..	150
Sargent, Fred W. (nee Delaware) ..	146	Sherwin, John	295
Sarnia City	326	Shiras, McGilvray	300
Sarnian	42	Shuniah	305
Sarnolite	179	Sicken, M.	418
Saskadoc	282	Siemens, Sir Wm.	300
Saskatchewan	42	Sierra	382
Saskatoon	42	Silver Spray	201
Satisfaction	147	Simcoe	42
Saturn	295	Simla	42
Saucon	19	Simpson, Lucia A.	343
Saugatuck	189	Simpson, Jos. W...	226
Saugatuck	347	Simpson, W. H. ..	63
Saunders, E. N. ..	152	Sinclair, James R.	145
Sawyer, W. H....	22	Sinmac	355
Schiller, Wm. B...	300	Sloat, Joseph T. ..	238
Schneider, A.E.R...	413	Smeaton, John ...	300
Schneider, Cletus..	69	Smith	326
Schoonmaker, Col. J. M.	353	Smith, Alfred H...	146
Schwab, Chas. M...	295	Smith, B. Lyman..	144
Scotsman	278	Smith Hurlbut W.	144
Scott, Archie	109	Smith, L. P.	141
Scott, T. J.	348	Smith, Leathem D.	357
Scout	248	Smith, Lyman C.	144
Seabird	200	Smith, Monroe C.	144
Seeandbee	65	Smith, Wilbert L.	144
Seither, Frank ...	17	Snyder, Jr., W. P.	353
		Sodus	110
		Sonora	270

Marine Iron & Ship Building Co.

Boiler Makers

Machinists

Carpenters

Foundrymen

Electric and
Acetylene Welders

Telephone: Melrose 735-6-7

Duluth, Minnesota

Vessel	Fleet No.	Vessel	Fleet No.
Soodoc	282	Stokes, Henry	97
Soreldoc	282	Stone, Amasa	295
South American ..	58	Stone Boy	315
Spalpeen	110	Stover, John R. ..	219
Spokane	221	Strathbogie	37
Spokane	327	Strathbungo	220
Spragge	221	Strathbuoy	98
Sprinkle, J. R.	419	Strathmore	98
Sprucebay	401	Strohn, C. B.	
Squatter	349	(see Lotus)	
Squire, F. B.	184	Stuart, M. H.	392
Squire, S. H.		Sullivan, J. J.	176
(see Cetus)		Sullivan, Roger C.	141
St. Anne De Beaupre		Sulphite	95
(nee Quebec)	42	Sultana	270
St. Lawrence	42	Sumac	409
St. Peter	159	Superior	222
Ste. Claire	92	Sweden	144
Stackhouse, Powell	156	Swederope	95
Stafford, W. R. ..	192	Sylvia	187
Stalker, Hugh	355		
Stanton, John	176	T. B. S.	377
Starke, Conrad	247	T. L. D. No. 1..	111
Starmount	42	T. J. S. No. 1.....	348
Steel Chemist	410	T. N. T.	370
Steel Electrician....	410	Tacoma	120
Steelmotor	410	Tadoussac	42
Steelton	19	Tampico	134
Steelvender	410	Taplin, Frank E...	426
Steinbrenner, H. ..	365	Tashmoo	423
Stephenson, Bob..	185a	Taurus	295
Stephenson, Geo...	300	Taylor, B. H.	28
Stephenson, Isaac	355	Taylor, J. Frater	3
Stephenson, I. W.	342	Taylor, S. G.	24
Stephenson, S. M.	38	Teed, Bob	147
Stewart	305	Tees, Thomas A...	277
Stewart, Donald ..	182	Templeton	44
Stewart, Emily ..	390	Ten	249
Stewart, Graeme..	59	Tennessee	145
Stewart, James ..	24	Tenno	130
Stewart, Mary.....	390	Texaco 157	374
Stewart, Murray ..	248	Texas	145
Stewart Robt. W.	363	Thistle	335
Stifel, William F.	193	Thom, John S....	316
Stillwater	204	Thomas, Sidney G.	300

MANITOWOC SHIPBUILDING CORPORATION

Manitowoc Wisconsin
Telephone 1040

Designers and builders of all types of Steam, Diesel and Diesel Electric propelled equipment, as follows:

- | | |
|-------------------|----------------|
| Freight Vessels | Dipper Dredges |
| Passenger Vessels | Sandsuckers |
| Self-unloaders | Dump Scows |
| Car-Ferries | Barges |
| Suction Dredges | Tugs |
| Pleasure Yachts | Car Floats |
| Fire Boats | Pontoons |

We also design and build Marine auxiliary equipment such as

- | | |
|------------------|--------------|
| Boilers | Gypsies |
| Marine Engines | Hawser Reels |
| Steering Engines | Chocks |
| Windlasses | Fairleaders |
| Winches | Towing Bitts |

A full line of engine room supplies and ship chandlery is carried in stock. Representatives for Vacuum Oil Co. oils and grease with stock on hand for immediate delivery.

Complete docking and repair facilities for handling all types of Marine repair work.

Vessel	Fleet No.	Vessel	Fleet No.
Thompson, C. A.	157	Upson, A. S.	198
Thompson, C. D.	111	Upson, J. E.	426
Thompson, D. P...	176	Uranus	194
Thompson, F. W.	339	Usona	134
Thompson, Smith..	144	Utica	146
Thordoc	282	Valcartier	42
Thunder Bay	42	Vandenberg, Miss	310
Tionesta	145	Vandoc	282
Thousand Islander	42	Vega	295
Toledo	145	Venus	194
Tomlinson, G. A.	176	Venus	295
Topping, John A.	193	Vercheres	248
Torain, George L.	24	Vermont	145
Toronto	42	Verona	295
Torrent	119	Victoria	36
Tourist	132	Victory	295
Townsend, E. Y...	39	Victory	375
Transfer	415	Vigilant	283
Transport	415	Viking	350
Tremaine, M. S...	25	Vinmount	42
Trevisa	403	Viper	390
Trillium	360	Virginia	145
Trimble, Richard..	300	Virginia	289
Triton	204	Virginia	355
Troisdoc	282	Wabash	8
Trois Rivieres	42	Waconta	4
Truby, John M...	145	Wahcondah	210
Truesdale, W. H.,	30	Wahnapiac	16
Turbinia	42	Wallace, Geo. A...	62
Turner, J. J.	152	Wallace, J. E.....	295
Turret Cape	231	Wallace Robt. B...	198
Turret Court	231	Walnero No. 2	
Twin	256	(see Alice C.	
Twin Cities	91	Murphy)	
Twin Ports	91	Walsh, James P...	176
Twins	2	Walter D.	111
Tyrone	129	Walter D.	377
Ufasco	406	Walters, Thomas..	183
Uhrig, Alex B....	329	Warmington	75
Uhrig, Edward A.	152	Warner, Wm. H...	384
Una	276	Warren	110
Underwood, F. E.	146	Warren, Wm. C...	384
United Luhmerman	317	Warrenco	315
United States	282		

Erie Machine Shops

P. W. Dietly, Prop.

We Have the Men
and
Necessary Machinery
for doing
High Class Marine Work

Give us a trial.

13th and Peach Streets

ERIE, PENNA.

Phone, Mutual 24107

Vessel	Fleet No.	Vessel	Fleet No.
Warwick, W. J...	29	Wild, Harry C.....	141
Washington	145	Wilkinson, H. S...	144
Waterbus	130	Willard, Daniel ...	146
Waterford	204	Williams, C. E....	141
Waterloo	42	Williams, H. D....	300
Waterton	236	Williams, J. L....	116
Watson, C. W...	383	Williams, J. R. ..	141
Watt, James	300	Willie H.	149
Waubauskene	50	Willowbay	402
Waukegan	145	Wilson, Anna C.	420
Waukegan	421	Wilson, G. N.	
Wauketa	94	(see Britt)	
Wawasee	419	Wilson, Mathew ..	202
Way. S. B.	411	Wilson, Capt. T...	426
Wayne	416	Windoc	282
Weavercoal	417	Windsolite	179
Weddell, Robt. G...	418	Windsor	265
Weed, Shelton	24	Winnipeg	42
Welcome	247	Winona	42
Wellandoc	282	Winyah	61
Werner, Henry P.	25	Wisconsin	136
West, B. E. (nee		Wisconsin	145
J. P. Manning)	48	Wisconsin	233
West, Charles C...	331	Witbeck, Henry...	355
Western States ..	90	Witch	353
Westland	327	Wolf, William H.	368
Westmount	42	Wolvin, A. B. ...	295
Weston, Frank ...	354	Wood, Joseph	154
Weyburn	42	Woodlands	355
Whalen, E. C.....	142	Woods, Frank	18
Whalen, James ...	98	Wotan	262
White, Peter	70	Wyandotte	432
White Star	42		
White Star	361	Yale	145
White, W. F. ...	28	Yorkton	236
White & Friant...	418	Young, John	159
Whitehall	204	Youngstown	295
Whitney, W. A....	424	Yosemite	68
Wiarion	236	Yukondoc	282
Wickwire, T. H...	23		
Wickwire, J., R. H.	23	Zenith City	300
Widener, P. A. B.	300	Ziesing, August ..	300

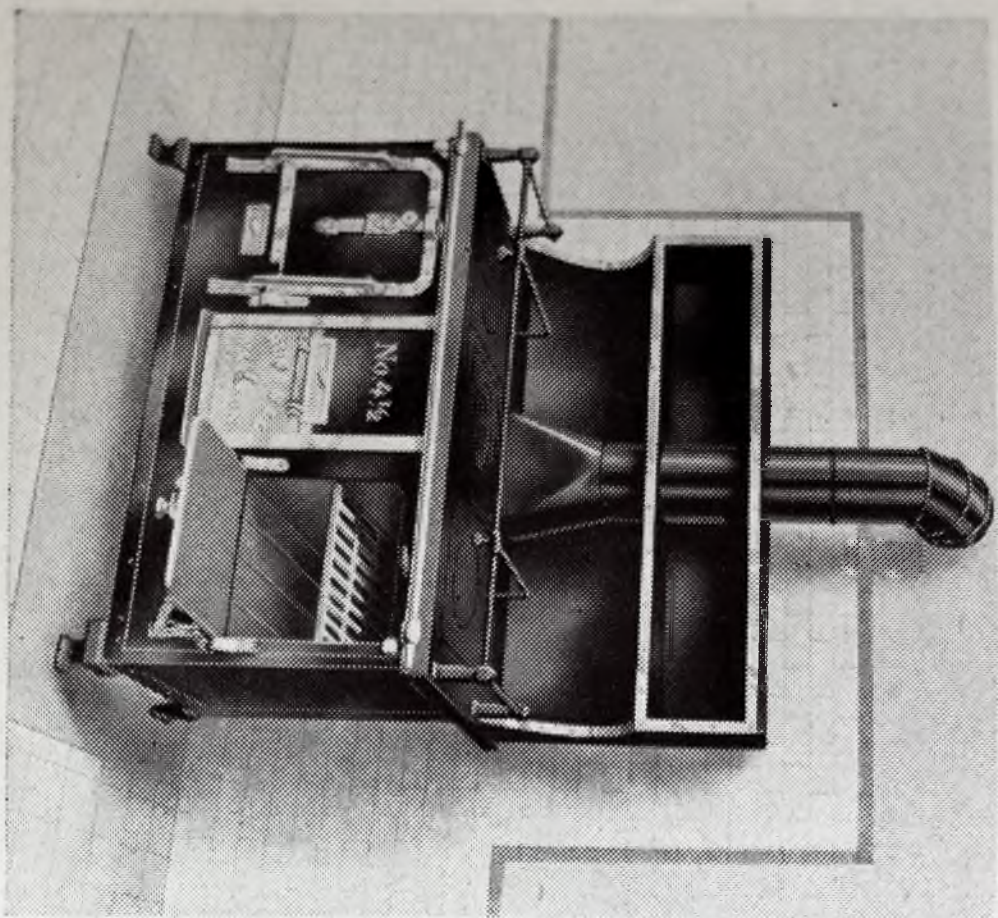

9 out of 10 Ships on the
Great Lakes Use
R & W GALLEY RANGES

Ask Your Steward
Standard Since 1857
Thru Your Dealer or Direct
RUSSELL & WATSON, Inc.
BUFFALO, N. Y.
Repairs at all ports

OWNERS, MASTERS AND ENGINEERS OF LAKE VESSELS

1. **Abbott, George C., North Port, Mich. (Owner and Operator)**
Tug Lillian A.....Capt. George C. Abbott.....Engr. George Smith
- 2 **Alexander, C. J., Dunkirk, N. Y. (Owner and Operator)**
Tug Grace B.Capt. Chas. W. Alexander...Engr.
Tug M. C. K.(Not in commission) Engr.
Gas TwinsCapt. Robert J. Alexander...Engr.
- 3 **Algoma Central Steamship Lines, Sault Ste. Marie, Ont. (Operator)**
(Algoma Central & Hudson Bay Railway Co.)(Owner)
W. J. McCormack, Superintendent A. M. MacInnes, Line Engineer
Str. W. C. FranzCapt. A. McIntyreEngr. A. M. MacInnes
Str. Home SmithCapt. Joseph Armstrong.....Engr. Wm. Tymon
Str. J. Frater TaylorCapt. M. A. LougheedEngr. Thos. Bogie
- 4 **Algoma Transit Co., c/o Soo Dock, Sault Ste. Marie, Ont. (Owner and Operator)**
Str. WacontaCapt. P. W. KentEngr. Thomas Love
- 5 **Allen, Curtis and Orin, Kewanee, Wis. (Owner and Operator)**
Tug Elsa M.Capt. Curtis AllenEngr. Orin Allen

6 Alpena Towing Co., Alpena, Mich. (Owner and Operator)
 Tug ChiefCapt.Engr.
 Tug W. F. Lahmann, Sr.....Capt.Engr.
 Tug OwenCapt.Engr.

7 American Construction Co., Marion Bldg., Cleveland, O., (Owner and Operator)
 Eli Coski, Superintendent

Tug Albatross(Appointments not available)
 Tug Aubrey(Appointments not available)
 Tug Princeton(Appointments not available)

American Steamship Co. (See Fleet No. 23)

8 Ann Arbor Railroad Co., Frankfort, Mich. (Operator)
 (Ann Arbor Railroad Co., Toledo, Ohio (Owner))

R. H. Reynolds, Marine Superintendent

C. F. Ann Arbor No. 3.....Capt. Louis HansenEngr. Mauritz Dahlgren
 C. F. Ann Arbor No. 4Capt. Albert Strauble.....Engr. Wm. Boyce
 C. F. Ann Arbor No. 5.....Capt. Chas. Frederickson.....Engr. Samuel Arneron
 C. F. Ann Arbor No. 6.....Capt. B. H. Hanson.....Engr. S. J. Hawkins
 C. F. Ann Arbor No. 7.....Capt. A. L. Larson.....Engr. Wm. L. Campbell
 C. F. WabashCapt. B. F. TulledgeEngr. O. T. Larson

9 Arnold Transit Co., Mackinac Island, Mich. (Owner and Operator)

Str. ElvaCapt. Samuel CarowEngr. Harry Moore
 Str. IslanderCapt. Louis GondreauEngr. Harry Lewis
 Str. D. P. PerryCapt. Louis GondreauEngr. Harry Lewis

10 Ashley & Dustin Steamer Line, 170 First St., Detroit, Mich.
 (Owner and Operator)

Str. Put-in-BayCapt. John N. Peterson.....Engr. Edward Gelnaw

Ashbay Steamship Co., Ltd. (See Fleet No. 393)

Aube Steamship Co., Ltd. (See Fleet No. 231)

11 Barlum, John J., Mgr., 2720 Grand River Ave., W., Detroit, Mich.
 (Operator) (Barlum Steamship Co.) (Owner)

Str. John J. Barlum.....Capt. A. J. Mahow.....Engr. Wm. C. Houston
 Str. Thomas Barlum.....Capt. R. A. Cain.....Engr. Luke Manion

12 Barnett & Record Co., The, Duluth, Minn. (Owner and Operator)

Tug Bayfield(Appointments not available)
 Tug Charley Ferris.....Capt. Ed. Moe.....Engr. Thomas Jones
 Tug John E. Meyer.....Capt. E. Miller.....Engr. Henry Oestrick

13 Bay of Quinte Transportation Co., Ltd., Pictou, Ont. (Owner and Operator)
 C. D. Wilson

Str. Glen Allan.....Capt. D. B. Christie.....Engr. John Gilbert Reid

14 Bay Transportation Co., The, Sandusky, O. (Owner and Operator)

Str. G. A. Boeckling.....Capt. Henry Witcher.....Engr. Adolph J. Stein
 G. L. AmericaCapt. Wilson Voight.....Engr. Wilson Voight

15 Beaubien Ice & Coal Co., 4205 W. Jefferson Ave., Detroit, Mich.
 (Owner and Operator)

Tug F. J. Haynes.....(Appointments not available)

16 Beck, C., Co., Ltd., Penetanguishene, Ont. (Owner and Operator)

Tug Beaverstone(Not in commission)
Tug Wahnapiac(Appointments not available)

17 Becker Steamship Co., Rockefeller Bldg., Cleveland, O. (Owner and Operator)
Capt. J. J. Freitus, Manager

Str. W. H. Becker.....Capt. A. A. Morrison.....Engr. Thos. E. Sheridan
Str. J. A. Donaldson.....Capt. E. W. May.....Engr. C. J. Dickey
Str. Michael Gallagher.....Capt. R. J. Neville.....Engr. A. M. Houston
Str. W. G. Pollock.....Capt. E. H. Bennett.....Engr. G. W. Kroening
Str. F. L. Robbins.....(Appointments not available)
Str. Frank Seither.....Capt. D. M. Post.....Engr. J. W. Long

Beechbay Steamship Co., Ltd. (See Fleet No. 394)

18 Benton Transit Co., 299 W. Main St., Benton Harbor, Mich. (Owner and Operator)

Str. BainbridgeCapt.Engr.
Str. Frank Woods.....Capt.Engr.

19 Bethlehem Transportation Corp., 1959 Union Trust Bldg., Cleveland, O. (Owner and Operator) Thomas W. Braund, Fleet Engineer.

Str. BethlehemCapt. M. Anderson.....Engr. Valentine Kraemer
Str. CambriaCapt. J. B. Sullivan.....Engr. N. A. Perry
Str. LackawannaCapt. George McGarry.....Engr. Stanley Hopton
Str. LebanonCapt. R. D. Peltier.....Engr. W. J. Cunningham
Str. LehighCapt. W. R. Jerome.....Engr. C. B. Culver
Str. MarylandCapt. Fred Sturtevant.....Engr. E. H. Parry

Str. SauconCapt. C. B. Gardner.....Engr. Fred Beebe
Str. SteeltonCapt. C. C. Balfour.....Engr. Edward F. Beger

20 Bielman, C. F., Foot Griswold St., Detroit, Mich. (Owner and Operator)

Str. C. F. Bielman, Jr.....Capt. John H. Flaherty.....Engr. Wm. Clark

Bison Steamship Corp. (See Fleet No. 272)

21 Blind River Transportation Co., Ltd., Blind River, Ont. (Owner and Operator) M. F. Dyke, Manager.

Tug J. McKeon.....(Not in commission) Engr.

22 Blodgett, O. W., 602 North Madison Ave., Bay City, Mich. (Operator)
(Each vessel listed below owned by a different company)

Str. Charles H. Bradley.....Capt. John M. Johnsen.....Engr. Oscar Tollefson
Str. CayugaCapt.Engr. George Hilbron
Str. KiowaCapt. Peter Ward.....Engr. Charles M. Robbins
Str. W. H. Sawyer.....(Appointments not available)
Sch. BrightieCapt. Wm. Johnson.....
Sch. GrampianCapt. Don Campbell.....
Sch. Nelson C. Holland.....Capt. S. T. Williams.....
Sch. A. B. King.....Capt. John O'Brine.....
Sch. MingoeCapt. O. L. Williams.....
Sch. M. W. Page.....Capt. Nils Tuner.....
Sch. PeshtigoCapt. Charles H. Osborne....

23 Boland & Cornelius, Mgrs., Marine Trust Bldg., Buffalo, N. Y. (Operator)
(American Steamship Co.) (Owner) S. E. Smith, Superintending Engineer of Fleet.

Str. John J. BolandCapt.Engr.
Str. Stephen M. Clement....Capt.Engr.

52

53

Str. Adam E. Cornelius.....	Capt.	Engr.
Str. Louis R. Davidson.....	Capt.	Engr.
Str. Frank H. Goodyear.....	Capt.	Engr.
Str. Hugh Kennedy.....	Capt.	Engr.
Str. Jacob T. Kopp.....	Capt.	Engr.
Str. Clifford F. Moll.....	Capt.	Engr.
Str. William P. Palmer.....	Capt.	Engr.
Str. G. F. Rand	Capt.	Engr.
Str. William T. Roberts....	Capt.	Engr.
Str. Theodore H. Wickwire	Capt.	Engr.
Str. Theodore H. Wickwire,				
Jr.	Capt.	Engr.
Str. Harry Yates.....	Capt.	Engr.

24 Boland & Cornelius, Mgrs., Buffalo, N. Y. (Operator)

(Eastern Steamship Co., Ltd.) (Owner)

S. E. Smith, Superintending Engineer of Fleet.

Str. Frank B. Baird.....	Capt.	Geo. M. Downey.....	Engr.	J. C. Carr
Str. Norman P. Clement....	Capt.	W. J. Hawman.....	Engr.	F. Black
Str. William H. Daniels.....	Capt.	A. H. Hogue.....	Engr.	A. Brown
Str. Edwin T. Douglass.....	Capt.	J. Earl McMurray....	Engr.	A. T. Burton
Str. Albert C. Field.....	Capt.	Chas. Sensabaugh.....	Engr.	Fortunate Mailhot
Str. Judge Hart.....	Capt.	Joseph H. Glass.....	Engr.	J. H. Carr
Str. J. A. Holloway.....	Capt.	Thos. E. Heffernan....	Engr.	John Scott
Str. Charles R. Huntley....	Capt.	I. L. Mateer.....	Engr.	M. E. Fowler
Str. Judge Kenefick.....	Capt.	R. J. Brown.....	Engr.	Geo. Fitzpatrick
Str. N. B. MacPherson.....	Capt.	A. E. Parrott.....	Engr.	Fred Tack

Str. Watkins F. Nisbet.....	Capt.	E. S. Bailey.....	Engr.	J. C. Dunn
Str. J. S. Pillsbury.....	Capt.	H. F. Hallifax.....	Engr.	Roy Milligan
Str. Robert W. Pomeroy....	Capt.	Harry Welbanks.....	Engr.	Allen Jenkins
Str. John J. Rammacher....	Capt.	A. E. Laking.....	Engr.	Alphonse Hamelin
Str. J. B. Richards.....	Capt.	W. F. Garnett.....	Engr.	Thos. Heatley
Str. James Stewart.....	Capt.	Arthur Cavanagh.....	Engr.	William Crowley
Str. S. G. Taylor.....	Capt.	H. J. Brian.....	Engr.	William D. McCann
Str. George L. Torain.....	Capt.	W. J. Ferguson.....	Engr.	F. A. Littlejohn
Str. William C. Warren....	Capt.	E. R. Jordon.....	Engr.	Geo. Bragg
Str. Shelton Weed.....	Capt.	J. E. McLeod.....	Engr.	William McMullen

25 Boland & Cornelius, Mgrs., Buffalo, N. Y. (Operator)

(Eastern Steamship Corp.) (Owner)

S. E. Smith, Superintending Engineer of Fleet.

Str. G. J. Grammer.....	Capt.	Engr.
Str. George H. Ingalls.....	Capt.	Engr.
Str. Inland	Capt.	Engr.
Str. Morris S. Tremaine....	Capt.	Engr.
Str. Henry P. Werner.....	Capt.	Engr.

26 Booth Fisheries Co., 205 North Michigan Ave., Chicago, Ill.

(Owner and Operator) (See Fleet No. 99)

Tug Alert	(Not in commission)	
Tug Baltimore	Capt. Alex Abrahamson.....	Engr. E. Hayes
Tug Chattanooga	Capt. E. G. Tuttle.....	Engr. Wm. Gleason
Tug Cincinnati	(Not in commission)	
Tug Courtney L.....	(Not in commission)	

Tug Hollis M.....Capt. Charles Winters.....Engr. George McNeil
 Tug LouisvilleCapt. Jacob Pfister.....
 Tug NashvilleCapt. Harry Johnson.....Engr. F. MacDougal
 Tug New York.....Capt. M. Anderson.....Engr. F. Matters
 Tug Philadelphia(Appointments not available)
 Tug Pittsburgh(Appointments not available)

27 Boyd, Harry H., 102 Chestnut St., Erie, Pa. (Owner and Operator)

Tug LibertyCapt. Harry H. Boyd.....

28 Bradley, Carl D., Mgr., Rogers, Mich. (Operator)

(Bradley Transportation Co.) (Owner)

Str. Carl D. Bradley.....Capt. Wm. J. MacLean.....Engr. John S. Sparre
 Str. CalciteCapt. Clayton A. Martin....Engr. John A. Anderson
 Str. John G. Munson.....Capt. Crossley McQuinn.... Engr. Arthur Urdal
 Str. T. W. Robinson.....Capt. M. R. MacLean.....Engr. Leif Urdal
 Str. B. H. Taylor.....Capt. F. F. Pearse.....Engr. Guy LaBounty
 Str. W. F. White.....Capt. Theo. Dahlburg.....Engr. Thos. Suttle

Bradley Transportation Co. (See Fleet No. 28)

29 Brigham, Charles, 164 Dearborn St., Buffalo, N. Y. (Owner and Operator)

Tug W. J. Warwick.....Capt. Samuel J. Brigham..Engr. Charles Brigham

30 Brown & Co., Mgrs., Chamber of Commerce Bldg., Buffalo, N. Y. (Operator)

(Brown Steamship Co.) (Owner)

Str. J. J. H. Brown.....Capt. Joseph R. Aston.....Engr. Fred Vieau

Str. W. H. Truesdale.....Capt. John A. MacDonald... Engr. Ray Hanel

31 Brown & Co., Mgrs., Chamber of Commerce Bldg., Buffalo, N. Y. (Operator)

(Iroquois Steamship Co.) (Owner)

Str. Inland(Appointments not available)

32 Brown, Harvey H., & Co., Mgrs., 1854 Union Trust Bldg., Cleveland, O.

(Operator) (Stewart Furnace Co.) (Owner)

Str. M. A. Bradley.....Capt. T. Howard Saunders Engr. Arthur Roberts
 Str. Fayette Brown.....Capt. T. Marshall Duddleson Engr. J. Emerson
 Str. Harvey H. Brown.....Capt. Thomas H. Saunders..Engr. Robert C. Cummings
 Str. Harry W. Croft.....Capt. W. L. Girardin..... Engr. W. J. McSweeney
 Str. Elton Hoyt II.....Capt. John J. Slade.....Engr. Arthur Butterworth

Brown Steamship Co. (See Fleet No. 30)

33 Brown, Worthy R., & Son, Lakeside, Ohio (Owner and Operator)

W. R. Brown.

Tug DispatchCapt.Engr.
 Tug Lakeside III.....Capt.Engr.

34 Buckeye Steamship Co., 1508 Rockefeller Bldg., Cleveland, O.

(Owner and Operator) John T. Hutchinson, Hutchinson & Co., Manager.

Str. BritonCapt. Geo. Wilson.....Engr. P. E. Sparre

Str. A. D. Macbeth.....Capt. Harold Jacobsen.....Engr. E. D. Butler

35 Buffalo & Crystal Beach Corp., Foot of Commercial St., Buffalo, N. Y.

(Owner and Operator) George C. Hall, President & General Manager.

Str. AmericanaCapt. Austin Wilcock.....Engr. Edward Smith

Str. CanadianaCapt. Alfred Johnson.....Engr. Frank Paddock

36 Buffalo Gravel Corp., 19 Hudson St., Buffalo, N. Y. (Owner and Operator)
R. W. Eberly, General Manager

Str. Weston M. Carroll.....Capt. Sherman S. Barnard....Engr. Eli Fontaine
Str. CrescentCapt. George Learman.....Engr. George Eberly
Str. Hyman(Not in commission)
Str. LakeportCapt. Charles NashEngr. Harry Raines
Str. VictoriaCapt. Harry KeeferEngr. William Hershey
Tug J. E. Carroll(Appointments not available)
Tug KingmanCapt. Harvey L. Shotwell.....Engr. Chester Hazen

Bunce Transit Co. (See Fleet No. 291)

37 Burke Towing & Salvage Co., Ltd., Midland, Ont. (Owner and Operator)
Edward F. Burke, Captain

Tug Fanny ArnoldCapt. Chas. MalcomEngr. Alfred Ferguson
Tug Lucknow(Appointments not available)
Tug Luckport(Appointments not available)
Tug StrathbogieCapt. Chas. LynnEngr. Jas. Readman
Bge. Allan No. 2Capt.Engr. George Graham

38 Burns, William, 1471 Hurlbut Ave., Detroit, Mich. (Owner and Operator)

Str. S. M. SephensonCapt.Engr.
Bge. DaytonCapt.Engr.
Bge. J. A. FrancombCapt.Engr.

Calumet Transportation Co., The (See Fleet No. 152)

39 Cambria Steamship Co., 1957 Union Trust Bldg., Cleveland, Ohio
(Owner and Operator)

Thomas W. Braund, Fleet Engineer

Str. Daniel J. MorrellCapt. B. M. LandfairEngr. LaForest Benson
Str. Edward Y. Townsend.....Capt. George B. BrockEngr. George Pennycook

40 Cameron Steamship Co., 1010 Francis Palms Bldg., Detroit, Mich.
(Owner and Operator)

John H. Cameron, Manager

Str. M. G. HauslerCapt.Engr. Art Burns

41 Canada Atlantic Transit Co., of U. S., 226 New Union Station, Toronto, Ont.
(Owner and Operator)

Str. CanatcoCapt. D. F. CornetEngr. C. Morrison
(nee Canadian Gunner)

Str. DalwarnicCapt. Jas. CuthbertEngr. A. McArthur
(nee Canadian Harvester)

Str. KearsargeCapt. John SimonsEngr. A. Jensen

Str. Arthur OrrCapt. J. E. FlemingEngr. W. Botsch

42 Canada Steamship Lines, Ltd., Montreal, Que. (Owner and Operator)

Str. AcadianCapt. J. CochraneEngr. J. King

Str. AdvanceCapt.Engr.

Str. AnticostiCapt. L. PatenaudeEngr. G. Reid

Str. ArabianCapt.Engr.

Str. ArvidaCapt. D. H. PorterEngr. J. Hamelin, Sr.

Str. AshcroftCapt. P. McKayEngr. H. Young

Str. Barrie	Capt. Roy Anderson	Engr. W. Hurder
Str. Beaverton	Capt. W. J. Holler	Engr. H. Paus
Str. Belleville	Capt.	Engr.
Str. Brentwood	Capt. J. A. Brown	Engr. L. S. Spencer
Str. Brignogan	Capt. D. Nolan	Engr. O. D. Thurston
Str. Calgarian	Capt. H. Baxter	Engr. J. Brooks
Str. Camrose	Capt. C. A. Martin.....	Egr. W. E. Downing
Str. Canadian	Capt. A. J. Story	Engr. A. Norris
Str. Canmore	Capt. J. B. Gamache	Engr. R. M. Bonnell
Str. Cape Diamond	Capt.	Engr.
Str. Cape Eternity	Capt. H. J. Little	Engr. A. Pageau
Str. Cape Trinity	Capt. H. J. Clarke	Engr. A. Chayer
Str. Cataract	Capt.	Engr.
Str. Cayuga	Capt. C. J. Smith	Engr. W. G. Taylor
Str. Chandler	Capt. D. C. McLachlan	Engr. F. Bonnell
Str. Chapleau	Capt. G. Lefebvre	Engr. W. B. Moore
Str. Chatsworth	Capt. L. Mongrain	Engr. G. Wismer
Str. Chippewa	Capt. Wm. Malcolm	Engr. J. M. Kennedy
Str. City of Hamilton.....	Capt. J. A. Lepine	Engr. S. Ashie
Str. City of Kingston	Capt. O. Patenaude	Engr. M. J. O'Brien
Str. City of Montreal	Capt. N. Legault	Engr. W. Casper
Str. City of Ottawa	Capt.	Engr.
Str. City of Toronto	Capt. J. A. Ferguson	Engr. M. J. Sherman
Str. City of Walkerville.....	Capt.	Engr.
Str. City of Windsor	Capt. E. Corcoran	Engr. J. Dyson
Str. Coalhurst	Capt.	Engr.
Str. Collier No. 1	Capt. T. J. Carson	Engr. J. J. Dove

Str. Collingwood	Capt. G. W. Pearson	Engr. H. J. Jack
Str. Corona	Capt. B. A. Bongard	Engr. C. Kniffen
Str. Courtright	Capt. B. F. Jones	Engr. A. Meikle
Str. Donnacona	Capt. J. H. Hudson	Engr. J. McGregor
Str. Dundas	Capt. A. W. Beatty	Engr. J. Hamelin, Jr.
Str. Edmonton	Capt. A. Francis	Engr. J. R. Naudie
Str. Elgin	Capt. C. Simpson	Engr. W. Goodwin
Str. Emperor	Capt. D. W. Burke	Engr. G. N. Smith
Str. Fairmount	Capt. J. J. Lawrence	Engr. A. Carrier
Str. Gleneagles	Capt. W. A. Lavigne	Engr. G. Price
Str. Glenelg	Capt. G. C. Kirk	Engr. T. W. Verity
Str. Glenmount	Capt.	Engr.
Str. Glenross	Capt. O. M. Wing	Engr. W. H. Carefoot
Str. Goderich	Capt. R. F. Pyette	Engr. P. Eagles
Str. Granby	Capt. H. A. Leaney	Engr. N. Parry
Str. Hagarty	Capt. A. F. MacLennan	Engr. I. J. Boynton
Str. Hamilton	Capt. P. Dussault	Engr. J. McFaul
Str. Hamonic	Capt. T. H. Johnston	Engr. J. W. McLeod
Str. Hastings	Capt. H. G. Redfern	Engr. J. Smith
Str. Huguenot	Capt. J. Shannon	Engr. J. B. Polding
Str. Huronic	Capt. T. S. Patterson	Engr. H. H. Moore
Str. Ignifer	Capt. A. C. Patterson	Engr. Geo. Cross
Str. Kamloops	Capt.	Engr.
Str. Kenora	Capt. C. Crompton	Engr. R. W. Hoews
Str. Kindersley	Capt. A. Allen	Engr. Geo. Fleming
Str. Kingston	Capt. A. E. Stinson	Engr. G. W. MacDonald
Str. Kinmount	Capt. B. Sullivan	Engr. J. M. Pendright

Str. Kipawa	Capt.	J. O. Beaudoin	Engr.	M. J. McFaul
Str. Knowlton	Capt.	A. E. DeMill	Engr.	W. Coburn
Str. Lanark	Capt.	V. Chartier	Engr.	D. Mercier
Str. Lemoyne	Capt.	C. E. Robinson	Engr.	D. Sinclair
Str. Lennox	Capt.	H. Laliberte	Engr.	D. Pruder
Str. Lethbridge	Capt.	Alex Wilson	Engr.	A. E. Kennedy
Str. Longueil	Capt.		Engr.	
Str. Macassa	Capt.		Engr.	
Str. Magog	Capt.	Geo. Dorais	Engr.	J. Bennett
Str. Maplecourt	Capt.	P. Beatty	Engr.	J. Kirk
Str. Mapleglen	Capt.		Engr.	
Str. Maplegorge	Capt.		Engr.	
Str. Maplegrange	Capt.		Engr.	
Str. Maplegreen	Capt.		Engr.	
Str. Mapleheath	Capt.	A. Wilson	Engr.	A. J. O'Brien
Str. Maplehill	Capt.	Wm. J. Hore	Engr.	J. Louden
Str. Mapleton	Capt.	J. M. Dumont	Engr.	M. Rankin
Str. Martian	Capt.	R. McIntyre	Engr.	H. Myler
Str. Meaford	Capt.	J. R. Lamarre	Engr.	U. Hamelin
Str. Midland King	Capt.	Roy Burke	Engr.	J. G. McHattie
Str. Midland Prince	Capt.	A. B. McIntyre	Engr.	J. A. Pickard
Str. Norfolk	Capt.	R. Sinclair	Engr.	E. C. Fleming
Str. Noronic	Capt.	H. J. Aitken	Engr.	S. Brisbin
Str. Oatland	Capt.		Engr.	
Str. Osler	Capt.	W. H. Montgomery	Engr.	R. R. Foote
Str. Oxford	Capt.	C. E. Scott	Engr.	J. A. MacDonald
Str. Penetang	Capt.	B. Martense	Engr.	L. Black

Str. Louis Phillippe	Capt.	J. N. Riverin	Engr.	J. Matte
Str. Ponoka	Capt.	J. A. McDowell	Engr.	J. Tuttle
Str. Portsmouth	Capt.	E. Walkinshaw	Engr.	M. Dedman
Str. Prescott	Capt.	Jas. Reoch	Engr.	W. C. Spencer
Str. Quebec	Capt.	A. Dube	Engr.	G. Morphey
Str. Rapids King	Capt.		Engr.	
Str. Rapids Prince	Capt.	Sam Putnam	Engr.	G. Gagnon
Str. Rapids Queen	Capt.	Wm. Blake	Engr.	E. Lenneville
Str. Renfrew	Capt.	W. Stalker	Engr.	M. Manners
Str. Renvoyle	Capt.	W. Taylor	Engr.	J. Silverthorne
Str. Richelieu	Capt.	C. H. Burch	Engr.	J. E. Kane
Str. Rosemount	Capt.	Wm. V. Myles	Engr.	J. Neville
Str. Royan	Capt.	N. Desmarais	Engr.	T. Gouin
Str. St. Lawrence	Capt.	A. H. M. Waterlow	Engr.	N. Peloquin
Str. St. Anne De Beaupre	Capt.	J. P. Stephenson	Engr.	O. Bonin
(nee Quebec)				
Str. Saguenay	Capt.	C. Waterhouse	Engr.	O. Peloquin
Str. Sarnian	Capt.	T. McLeod	Engr.	D. J. Leslie
Str. Saskatchewan	Capt.	J. J. Dube	Engr.	R. Sinclair
Str. Saskatoon	Capt.	Fred Irish	Engr.	F. Lumley
Str. Selkirk	Capt.	E. F. Raeburn	Engr.	D. Simons
Str. Sherbrooke	Capt.	L. Pregent	Engr.	V. Parker
Str. Simcoe	Capt.	E. Griesbach	Engr.	T. Nichols
Str. Simla	Capt.		Engr.	
Str. Starmount	Capt.	J. W. Scarrow	Engr.	J. A. Gunn
Str. Tadoussac	Capt.	W. Gagne	Engr.	N. Crepeau
Str. Thousand Islander	Capt.	P. McIntyre	Engr.	

Str. Thunder Bay	Capt. Albert Bonin	Engr. F. Tousignant
Str. Toronto	Capt. E. A. Booth	Engr. J. F. Henry
Str. Trois Rivieres	Capt.	Engr.
Str. Turbinia	Capt.	Engr.
Str. Valcartier	Capt. A. M. Wright	Engr. A. J. McChristie
Str. Vinmount	Capt. M. Corkey	Engr. Geo. Clark
Str. Waterloo	Capt. E. Poirier	Engr. C. Barlow
Str. Westmount	Capt. J. F. Davis	Engr. C. Leriche
Str. Weyburn	Capt. J. L. Baxter	Engr. R. H. Isbester
Str. White Star	Capt.	Engr.
Str. Winnipeg	Capt. H. A. Patterson	Engr. Jas. Douglas
Str. Winona	Capt. A. M. Sparling	Engr. R. G. Wilkinson
Bge. Brighton	Capt.	Engr.
Bge. J. R. Edwards	Capt.	Engr.
Bge. Jeremiah Godfrey	Capt.	Engr.
Bge. Minnie E. Orton	Capt.	Engr.

43 Canadian Dredging Co., Ltd., Midland, Ont. (Owner and Operator)

Tug Brant	Capt. F. Lymburner	Engr. J. Cornett
Tug A. M. German	Capt. A. Lymburner	Engr. Robt. Beatty
Tug F. W. Grant	Capt. J. Gillem	Engr. N. Taylor
Tug Hector	Capt.	Engr. Wm. Taylor
Tug Con Lynch	Capt. H. Gehl	Engr. Jos. Hamley
Tug Laird MacAuley	Capt. S. Ahern	Engr. Geo. Young
Tug Mendora	Capt. W. Julian	Engr. Wm. Wright
Tug G. W. Rogers	Capt. C. Moore	Engr. Wm. Gehl

Canadian Government Railways "Canadian National Rys." (See Fleet No. 266)

44 Canadian International Paper Co., Ltd., Ottawa, Ont. (Owner and Operator)

Tug Chelsea	Capt. Abram Osborne	Engr. Hans Christensen
Tug Pythonga	Capt. W. C. Russell	Engr. Matt Walton
Tug Russell	Capt. Chas. Cropley	Engr. Nap Lepine
Tug Templeton	Capt. Albani Malette	Engr. H. C. Rundle

Canadian National Railways (See Fleet Nos. 139, 266 and 267)

**45 Canadian Oil Companies, Ltd., Toronto, Ont. (Operator)
(Sarnia & Toledo Transit Co.) (Owner)**

Bge. En-ar-co	Capt. E. S. Taylor	Engr.
---------------------	--------------------------	------------

**46 Canadian Pacific Car & Passenger Transfer Co., Ltd., Prescott, Ont.
(Owner and Operator)**

C. F. Charles Lyon	Capt. A. R. Henry	Engr. A. C. Stillson
--------------------------	-------------------------	----------------------

47 Canadian Pacific Railway Co., Montreal, Que. (Owner and Operator)

M. McD. Duff, Manager Great Lakes Steamship Service

Str. Alberta	Capt. F. S. Middleton	Engr. F. W. Irvine
Str. Assiniboia	Capt. J. McCannel	Engr. A. A. Cameron
Str. Athabasca	Capt. M. McKay	Engr. G. S. Rae
Str. Keewatin	Capt. M. McPhee	Engr. G. D. Adam
Str. Manitoba	Capt. F. J. Davis	Engr. W. S. Struthers

**48 Candler Dock & Dredge Company, 8145 Medina St., Detroit, Mich.
(Owner and Operator)**

Tug B. E. West	Capt. B. E. West	Engr. J. S. Miller
----------------------	------------------------	--------------------

(nee J. P. Manning)

49 **Carow Towing Co., Cheboygan, Mich. (Owner and Operator)**
O. B. Martin, Manager
Tug LotusCapt.Engr.

50 **Carpenter-Hixon Co., Ltd. (Owner and Operator)**
Tug N. Dymont(Appointments not available)
Tug WaubausheneCapt. J. C. KauffmanEngr. D. A. McLeod

51 **Carroll Brothers, 488 Ellicott Square, Buffalo, N. Y. (Owner and Operator)**
Tug J. M. Hutchinson(Not in operation)

52 **Carrollton Steamship Co., Saginaw, Mich. (Operator)**
(Carrollton Steamship Co., Carrollton, Mich.) (Owner)
Str. Langell BoysCapt. Bert PayeaEngr. J. W. Giddings

53 **Carter Wood Lines, Ltd., 75 Common St., Montreal, P. Q. (Owner and Operator)**
Str. ChemongCapt. Ernest TremblayEngr. Robert Knight
Str. DrumahoeCapt. Frank A. GarrettEngr. W. A. McWilliam

54 **W. A. Cartier, Ludington, Mich. (Owner and Operator)**
Str. Missouri(Appointments not available)

Cedarbay Steamship Co., Ltd. (See Fleet No. 395)
55 **Central Dredging Co., Union Trust Bldg., Cleveland, O. (Owner and Operator)**

Str. Bay ViewCapt. J. McGarryEngr. C. Diersen
Str. Chicago(Appointments not available)
Str. Frank Rockefeller(Appointments not available)
Tug Manomet(Appointments not available)
Tug James T. Martin(Appointments not available)

66

Central Transportation Co. (See Fleet No. 170)

Chamberlin, Frank E. (See Fleet No. 311)

56 **Charland, Emile, Ltd., 468 William St., Montreal, P. Q. (Owner and Operator)**
Str. Susie ChipmanCapt.Engr.

57 **Chicago & South Haven Steamship Co., Clark St. Bridge, Chicago, Ill.**
(Owner and Operator) C. H. Beigh
Str. IroquoisCapt. Frank A. DorityEngr. Walter A. Doran

58 **Chicago, Duluth & Georgian Bay Transit Co., 110 W. Adams St., Chicago, Ill.**
(Owner and Operator)

Str. North AmericanCapt. Wm. T. BrightEngr. Harry J. Wilson
Str. South AmericanCapt. Andrew C. Anderson....Engr. Henry C. Hankans

59 **Chicago Fire Department, Chicago, Ill. (Operator) (City of Chicago) (Owner)**
Tug IllinoisCapt. Thomas FarrelEngr. Geo. McClane
Tug Joseph MedillCapt. James HallahanEngr. Chas. Huddleston
Tug Graeme StewartCapt. Oliver LandrethEngr. M. Murphy

Chicago Navigation Co. (See Fleet No. 367)

60 **Chicago Tribune Transportation Co., Ltd., 810 Shaughnessy Bldg., Montreal, Que.**
(Owner and Operator) H. L. Beauvais, Marine Superintendent
Str. Chicago TribuneCapt. F. V. McIntyreEngr. E. Scott
Str. New York NewsCapt. Geo. FergusonEngr. L. Vipond

61 **Christiansen, H., & Son, Duluth, Minn. (Owner and Operator)**
Martin Christiansen, Port Captain

Str. HazelCapt. M. ChristiansenEngr. Geo. Chacklick
Str. WinyahCapt. Ole BergEngr. O. E. Christiansen

67

City of Buffalo (See Fleet No. 87)

City of Chicago (See Fleet No. 59)

62 City of Cleveland, Cleveland, Ohio (Owner and Operator)

Tug J. C. FarleyCapt. Frank A. HearnnesEngr. J. R. Dempsey
Tug George A. Wallace.....Capt. James DeverEngr. Wm. Dempsey

63 City of Detroit, Department of Parks and Boulevards, 600 Marquette Bldg.,
Detroit, Mich. (Owner and Operator) George H. Patton

Tug George H. PattonCapt. Hugh McKenzieEngr. John Miller
Tug W. H. SimpsonCapt.Engr.

City of Milwaukee (See Fleet No. 119)

64 City of Three Rivers, Three Rivers, Que. (Owner and Operator)

Str. Le ProgressCapt. Hector DuvalEngr. Irene Jourdain

65 Cleveland & Buffalo Transit Co., East 9th St. Pier, Cleveland, Ohio
(Owner and Operator) Charles Lorimer, Superintending Engineer of Fleet

Str. City of BuffaloCapt. A. H. MacLachlanEngr. D. D. Donaldson
Str. City of ErieCapt. E. S. PickellEngr. Wm. Robinson
Str. Good TimeCapt. R. SpurrierEngr. A. Greb
Str. SeeandbeeCapt. Neil McPhailEngr. Geo. Turnbull

66 Cleveland & Canada Navigation Co., E. 9th St. Pier, Cleveland, Ohio
(Owner and Operator)

Str. City of St. Ignace.....Capt. Ralph SpurrierEngr. Harry C. Kennedy

67 Cleveland-Cliffs Iron Co., 1460 Union Trust Bldg., Cleveland, Ohio (Operator)
(Cleveland-Cliffs Steamship Co.) (Owner)

C. O. Rydholm, Fleet Captain James H. Durkin, Fleet Engineer

Str. CadillacCapt.Engr.
Str. FrontenacCapt.Engr.
Str. Grand IslandCapt.Engr.
Str. IshpemingCapt.Engr.
Str. MarquetteCapt.Engr.
Str. William G. MatherCapt.Engr.
Str. MichiganCapt.Engr.
Str. MunisingCapt.Engr.
Str. NegauneeCapt.Engr.
Str. PioneerCapt.Engr.
Str. PontiacCapt.Engr.
Str. J. H. SheadleCapt.Engr.
G. L. OttawaCapt.

68 Cleveland-Cliffs Iron Co., 1460 Union Trust Bldg., Cleveland, Ohio (Operator)
(Fontana Steamship Co.) (Owner)

C. O. Rydholm, Fleet Captain James H. Durkin, Fleet Engineer

Str. ColonelCapt.Engr.
Str. SenatorCapt.Engr.
Str. YosemiteCapt.Engr.

69 Cleveland-Cliffs Iron Co., 1460 Union Trust Bldg., Cleveland, Ohio (Operator)
(Paisley Steamship Co.) (Owner)

C. O. Rydholm, Fleet Captain James H. Durkin, Fleet Engineer

Str. BartelmeCapt. T. J. CrockettEngr. Wallace Ives
(nee Central West)

Str. Robert J. Paisley.....Capt.Engr.
 Str. NelsonCapt. Herman OertlingEngr. A. W. Muhlitner
 (nee Panay)
 Str. Cletus Schneider.....Capt.Engr.
70 Cleveland-Cliffs Iron Co., 1460 Union Trust Bldg., Cleveland, Ohio (Operator)
 (Presque Isle Transportation Co.) (Owner)
 C. O. Rydholm, Fleet Captain James H. Durkin, Fleet Engineer
 Str. AngelineCapt.Engr.
 Str. Presque Isle.....Capt.Engr.
 Str. Peter White.....Capt.Engr.
71 Cleveland-Cliffs Iron Co., 1460 Union Trust Bldg., Cleveland, Ohio (Operator)
 (Progress Steamship Co.) (Owner)
 C. O. Rydholm, Fleet Captain James H. Durkin, Fleet Engineer
 Str. FontanaCapt.Engr.
72 Cleveland Transportation Co., 1461 Union Trust Bldg., Cleveland, Ohio
 (Owner and Operator) A. E. R. Schneider, Manager
 Str. LewistonCapt.Engr.
 Cleveland-Cliffs Steamship Co. (See Fleet No. 67)
73 Clow & Nicholson Transportation Co., Duluth, Minn. (Owner and Operator)
 Str. MontaukCapt. B. J. Roberts.....Engr.
 Columbia Steamship Co. (See Fleet No. 193)
 Commonwealth Coal Co. (See Fleet No. 292)
74 Connelly Bros., 165 Ohio St., Buffalo, N. Y. (Owner and Operator)
 Tug Connelly Bros. No. 1..Capt.Engr.
 Tug Connelly Bros. No. 2..Capt.Engr.

70

75 Consolidated Sand Co., Ltd., 270 Ottawa St., Montreal, Que. (Owner and Operator)

Str. Pennsylvania (Appointments not available)
 Bge. Fred Carney..... (Appointments not available)
 Bge. C. W. Chamberlain..... (Appointments not available)
 Bge. Cobalt (Appointments not available)
 Bge. Gladys-H (Appointments not available)
 Bge. Ireland (Appointments not available)
 Bge. LaSalle (Appointments not available)
 Bge. Muskoka (Appointments not available)
 Bge. Warmington (Appointments not available)

76 Construction Materials Co., 133 W. Washington St., Chicago, Ill.
 (Owner and Operator) J. R. Sensibar

Bge. L. L. Barth.....Capt.Engr.
 Str. SandcraftCapt.Engr.
 Tug FreedomCapt.Engr.
 (nee Corona)
 Tug Robert E. Johnston.....Capt.Engr.
 Tug LibertyCapt.Engr.
 Bge. AuroraCapt.Engr.
 M. S. Sandmaster.....Capt.Engr.

Continental Steamship Co. (See Fleet No. 379)

77 Couture Bros. Fish Co., Ontonagon, Mich. (Owner and Operator)

Tug EagleCapt. Russell Couture.....Engr. Frank Sager
 Tug RecordCapt. Earl J. Couture.....Engr. James Patterson

71

78 Cowles Towing Co., 360-370 Ohio St., Ohio Basin Terminal, Buffalo, N. Y.
(Owner and Operator)

	John Wilke, Fleet Captain	R. Garrity, Engineer
Str. Crescent	Capt. Roy Oatman.....	Engr. Walter McDonald
Tug Buffalonian	Capt. Frank Williams.....	Engr. W. Bond
Tug Carlotta	Capt. Alpha Kramer.....	Engr. J. Ruane
Tug Ross Coddington.....	Capt. Thos. Lally.....	Engr. L. Albright
Tug Cotoco	Capt. Phil Brigham.....	Engr. I. Curtin
Tug Benj. L. Cowles.....	Capt. Bert Oakley.....	Engr. I. Fitzgerald
Tug Lotta L. Cowles.....	Capt. Ernest Kraft.....	Engr. I. W. Shain
Tug Wm. G. Fox.....	Capt. Wm. Murphy.....	Engr. G. Fitzgerald
Tug Ed. Lanahan.....	Capt. Bert Senn.....	Engr. P. Brigham
Tug John Lenahan.....	Capt. Christ Boeck.....	Engr. C. Eaton
(nee Oswegatchie)		
Tug Liberty	Capt. John Wilke.....	Engr. R. Garrity
Tug Alice C. Murphy.....	Capt. Fred Tuttle.....	Engr. J. Sutton
(nee Walnero No. 2)		
Tug W. M. Peckham.....	(Not in commission)	
Tug Rochester	Capt. T. D. Griffin.....	Engr. M. Bodkin
Tug Service	Capt. Leo Gorham.....	Engr. T. Higgins
79	Cox, Charles W., Ltd., Port Arthur, Ont. (Owner and Operator)	
Tug Jessie Hall.....	Capt. Albert Trembley	Engr. Jack Neil
80	Cram, R. H., Ottawa, Ont. (Owner and Operator)	
Str. R. Anglin.....	Capt.	Engr.
81	Crowells, E. J., 158 Marlborough, Detroit, Mich. (Operator) (Leathem Smith-Cliffs Co.) (Owner)	
Str. Andaste	Capt. A. J. Hanna.....	Engr. Edward Hulbert

72

82 Crowells, E. J., 158 Marlborough, Detroit, Mich. (Operator)
(Smith-Truby Sand Co.) (Owner)

Str. Bay State.....	Capt. Wm. Martin.....	Engr. Arthur Wilkins
83	Cullnan, P. J., 1909 Newport Ave., Chicago, Ill. (Operator) (Cullnan & Walsh) (Owner) P. W. Walsh	

- Tug Fred A. Britten..... (Not operating)
- Tug John Cullnan..... (Not operating)
- Tug Josephine

Cullnan & Walsh (See Fleet No. 83)

Dalhousie Navigation Co. (Canadian National Rys.) (See Fleet No. 267)

84 Daryaw, Capt. Henry, 20 Rideau St., Kingston, Ont. (Owner and Operator)	
Sch. Lyman M. Davis.....	Capt. H. Daryaw.....
85 Davidson Steamship Co., Duluth, Minn. (Owner and Operator)	James Davidson
Str. Cottonwood	Capt. J. E. Fick.....
Str. Lake George.....	Capt. Chas. Rionn.....
Str. Sacramento	Capt.
Sch. Chieftain	Capt.
Sch. Montezuma	Capt. Rudolph Peterson.....
86 DeHaas, N. M., 413 E. Michigan St., Marquette, Mich. (Owner and Operator)	
Tug Nellie Cotton....	(Not in commission)
87 Department of Fire, Buffalo, N. Y. (Operator) (City of Buffalo) (Owner)	
Str. W. S. Grattan.....	Capt. Daniel J. Mahoney... Engr. Daniel A. Martin
Tug George R. Potter.....	(Appointments not available)
88	Department of Public Works, Ottawa, Ont. (Owner and Operator)
Tug Hercules	Capt. N. Jackson.....
Tug Peel	Capt. G. W. Blanchard.....

73

Dredge No. 1 Q & R.....Capt. M. Convey.....Engr.
 Dredge P.W.D. No. 109.....(Not in commission)
 Dredge P.W.D. No. 117.....Capt. R. Hogan.....

89 Department of Railways & Canals, Ottawa, Ont. (Owner and Operator)

Tug BatchawanaCapt. George Bridge.....Engr. Geo. E. Coe
 Tug W. A. Bowden.....Capt. Cory Hart.....Engr. Frank Moyle
 Tug Bessie Butler.....Capt. James A. Johnson.....Engr. Wm. Gillman
 Tug LorettaCapt. Ed. Fleming.....Engr. O. Seguin

90 Detroit & Cleveland Navigation Co., Detroit, Mich. (Owner and Operator)
 A. A. Schantz, President C. L. Perkins, Assistant General Manager J. P. Wells,
 Supt. Hulls & Machinery

Str. City of Cleveland III..Capt. John Lightbody.....Engr. Albert Murphy
 Str. City of Detroit III.....Capt. A. J. Palmer.....Engr. Wm. Hoppe
 Str. Eastern States.....Capt. O. W. Grose.....Engr. Wm. Woodrow
 Str. Greater Buffalo.....Capt. L. C. DeNike.....Engr. M. E. Sicklesteel
 Str. Greater Detroit.....Capt. Fred H. Fauls.....Engr. Andrew Carter
 Str. Western States.....Capt. J. A. Hyatt.....Engr. L. Nattress

91 Detroit-New York Transit Co., W. Jefferson at Clark Ave., Detroit (Owner and Operator)

Str. Twin Cities.....Capt. Martin Peterson.....Engr. Jos. F. Pinkham
 Str. Twin Ports.....Capt. Fred Premo.....Engr. Odin Johnson

92 Detroit & Windsor Ferry Co., Detroit, Mich. (Owner and Operator)
 Herbert Balfour, Chief Engineer

Str. BritanniaCapt. Henry Heyser.....Engr. Lester Hessong
 Str. CadillacCapt. Archibald Bain.....Engr. Daniel Reid
 Str. ColumbiaCapt. Jno. J. Denstaedt.....Engr. Edward Seymour

Str. La Salle.....Capt. Henry Pocock.....Engr. Archie Wright
 Str. PappooseCapt. R. C. Brown.....Engr. Joseph Marks
 Str. PleasureCapt. Jno. Richards.....Engr. Malcolm Campbell
 Str. PontiacCapt. L. P. Anderholt.....Engr. Simon Merrill
 Str. PromiseCapt. Damase Jacques.....Engr. Edward Thrombley
 Str. Sappho(Not in commission)
 Str. Ste. Claire.....Capt. Chas. Anderson.....Engr. William Nolan

93 Detroit Fire Department, 3434 Russell St., Detroit, Mich. (Owner and Operator)
 Edward C. Rumsey

Tug James Battle.....Capt. Joseph E. Jones.....Engr. Alexander Roach
 Tug James R. Elliott.....Capt. Hubert H. Skiffington Engr. George P. Seiler

94 Detroit-Port Huron Steamship Co., Foot of Griswold St., Detroit, Mich. (Owner and Operator)

Str. WauketaCapt. Christian Smith.....Engr. James D. MacCallum

95 Detroit Sulphite Transportation Co., 9125 W. Jefferson Ave., Detroit, Mich. (Owner and Operator)

L. Hulbert, Port Captain Paul Zilske, Superintending Engineer
 Tug SulphiteCapt. A. M. Peterson.....Engr. John Hilton
 Bge. CordovaCapt. Edw. Thorne.....Engr. E. Peterson
 Bge. MitschfibreCapt. Peter Johansen.....Engr. Fred Wilkensen
 Bge. SwederopeCapt. Theodore Birkeland....

Detroit Trust Co. (See Fleet No. 123)

96 Dixon, H. J., Toronto, Ont. (Owner and Operator)

Tug A. E. Gibson.....Capt. Wm. Akel.....Engr. Hugh MacMillan
 Tug Prince Ray.....(Appointments not available)

97 Dominion Sugar Co., Ltd., Wallaceburg, Ont. (Owner and Operator)

Tug Acadia Capt. Engr.
Tug William E. Rooney..... Capt. Engr.
Tug Henry Stokes..... Capt. Engr.

98 Dominion Towing & Salvage Co., Ltd., 714 Whalen Bldg., Port Arthur, Ont.

(Owner and Operator) W. E. Mutch, Superintendent

Tug A. F. Bowman..... Capt. A. McDonald..... Engr. Jas. Keenan
Tug H. F. Bronson..... Capt. E. J. Cadotte..... Engr. L. J. Bigg
Tug Champlain Capt. Engr. Wm. Hillard
Tug Strathmore Capt. V. McCabe..... Engr. J. Farquharson
Tug James Whalen..... Capt. B. Burke..... Engr. J. Gehl
Bge. Melvin S. Bacon..... Capt. Engr.
Bge. Coteau Capt. Engr.
Bge. Green River..... Capt. Engr.
Der. Bge. Empire Capt. T. Bare Engr.
Der. Bge. Strathbuoy Capt. H. Newton..... Engr.

76

99 Dominion Transportation Co., Ltd., 205 North Michigan Ave., Chicago, Ill.

(Operator) (Booth Fisheries Co.) (Owner)

Str. Caribou Capt. A. A. Batten..... Engr. J. Walters
Str. Manitou Capt. N. J. McCoy..... Engr. A. Glendillen

100 Dominion Transportation Co., Ltd., Owen Sound, Ont., (Owner and Operator)

Str. Hibou Capt. N. Barrett Engr. A. Wilson
(nee Alice)
Str. Henry Pedwell..... (Not in operation)

101 Donnelly Salvage & Wrecking Co., Ltd., Kingston, Ont. (Owner and Operator)
John Kennedy, Superintendent.

Lighter Harriett D..... Capt. Jack Hart.....

102 Donnelly Salvage & Wrecking Co., Kingston, Ont. (Operator)
(John Donnelly) (Owner)

Tug Donnelly Capt. Robt. Siddell..... Engr. Rollie Mullin
Tug Frontenac Capt. W. J. Phelix..... Engr. Thos. Compeau
Tug Mary P. Hall..... Capt. Luke Mallan..... Engr. Herbert Moore
Tug William Johnston..... Capt. John Martin.....
Bge. Cobourg Capt. Joseph Compeau.....
Lighter Mamie..... Capt. Morel Compeau.....

103 Donnelly Salvage & Wrecking Co., Kingston, Ont. (Operator)

(John Donnelly and Estate Thos. Donnelly) (Owner) John Kennedy, Superintendent

Str. Cornwall Capt. W. J. Phelix..... Engr. Wm. Kennedy

Donner Steamship Co., The (See Fleet No. 153)

104 Doty Engineering Co., Ltd., 209 York Bldg., Toronto, Ont.
(Owner and Proprietor)

Str. Missisquoi Capt. Engr. George E. Potts

105 DoVille Lake Sand & Gravel Co., 424 Water St., Toledo, Ohio
(Owner and Operator) R. E. DoVille, Port Captain and Engineer of Fleet.

Str. Commerce Capt. Otto Rose..... Engr. H. E. McNutt
Str. R. E. DoVille..... Capt. D. A. McQuade..... Engr. Wm. W. Winne

106 Duluth & Iron Range Railroad Co., The, Duluth, Minn. (Owner and Operator)
Thomas Owens, Vice President and Superintendent.

Tug Edna G..... Capt. Henry G. Fox..... Engr. Fabien Poulin

77

107 **Duluth Marine Supply Co., Duluth, Minn. (Owner and Operator)**
 Tug. IslayCapt. John Newman.....Engr. Elmer Casper
 G. L. BugCapt. Leo Cudinski.....
 G. L. Simon Clark.....Capt. Emil Gustafson.....
 G. L. Hallan Bros.....Capt. Jack Needs.....

108 **Duluth, Missabe & Northern Railway Co., Duluth, Minn. (Owner and Operator)**
 Tug Wm. A. McGonagle...Capt. M. E. Glenn.....Engr. Sam E. DeMore

Duluth Steamship Co. (See Fleet No. 380)

109 **Duluth Superior Dredging Co., Duluth, Minn. (Owner and Operator)**
 Tug Alfred W.....(Appointments not available)
 Tug GladiatorCapt. Albert Bourassa.....Engr. Archie Scott
 Tug John Navagh.....(Appointments not available)
 Tug Archie Scott.....(Appointments not available)

110 **Dunbar & Sullivan Dredging Co., Erie Co. Bank Bldg., Buffalo, N. Y. (Operator) (Dunbar & Sullivan Dredging Co., Detroit) (Owner)**

Tug Martin J. Gillen.....Capt. Ed. Bebeau.....Engr. C. Anderson
 Tug SachemCapt. Wm. Ziem.....Engr. J. Bainbridge
 Tug ShaughraunCapt. J. Wallace.....Engr. J. Staley
 Tug Shaun Rhue.....Capt. J. McLean.....Engr. W. Shewfelt
 Tug SodusCapt. E. Tobin.....Engr. G. Whitten
 Tug SpalpeenCapt. F. Godfrey.....Engr. H. Green
 Tug Warren(Not in commission)

111 **Durocher, T. L., Co., De Tour, Mich. (Owner and Operator) W. W. Durocher.**
 Tug GeneralCapt. E. J. Potvin.....Engr. James R. Sherry
 Tug C. D. Thompson.....Capt. J. S. Deerwood.....Engr. Harold Mullen
 Tug Walter D.....Capt. Leslie Bell.....Engr.

Bge. Derk, De Tour.....Capt. Alfred Leask.....Engr.
 Bge. T. L. D. No. 1.....Capt. Jos. Beatty.....

Eastern Steamship Co., The (See Fleet No. 154)

Eastern Steamship Co., Ltd. (See Fleet No. 24)

Eastern Steamship Corp. (See Fleet No. 25)

112 **Eaton-Edmonds Fish Co., South Haven, Mich. (Owner and Operator)**
 Tug Robbins 3.....(Not in commission)

113 **Eldridge & Robinson, Auburn, N. Y. (Owner and Operator)**
 Str. M. G. Phelps.....Capt. P. Phelps.....Engr. B. J. Manwarring

Elmbay Steamship Co., Ltd. (See Fleet No. 396)

114 **Emery, W. L., 28 Campau Bldg., Detroit, Mich. (Owner and Operator)**
 Str. John R. Emery.....Capt. Delos LaffreyEngr. Leon Bourlier

115 **Emig, Capt. T., 1075 Hart Rd., St. Clair, Mich. (Owner and Operator)**
 Str. R. P. Fitzgerald.....Capt.Engr.

Empress Navigation Co., Ltd. (See Fleet No. 161)

116 **England Towing Co., 1930 East 5th St., Duluth, Minn. (Owner and Operator)**
 Tug J. L. Williams.....Capt. W. F. Thompson.....Engr. Charles McEachin
 Bge. AcmeCapt. Wm. Laurence.....Engr. M. A. Poliquin

117 **Essex Transit Co., Ltd., Ford, Ont. (Owner and Operator)**
 Tug FlorenceCapt. G. T. Motley.....Engr. F. A. Presley
 Bge. Great Western.....Capt. John Sway.....Engr.

118 **Evans, Royal G., Cheboygan, Mich. (Owner and Operator)**
 Tug Burger(Appointments not available)

119 Fire Department, The, Milwaukee, Wis. (Operator)
 (City of Milwaukee) (Owner) Peter Steinkellner, Chief Fire Dept.
 Fireboat M.F.D. No. 15.....Capt. Max Etzel.....Engr. Thos. Rutherford
 Fireboat M.F.D. No. 17.....Capt. Jerry Sullivan.....Engr. R. Schneidewind
 Fireboat M.F.D. No. 29.....Capt. Jos. SaGue.....Engr. Peter DeSmedt
 Fireboat TorrentCapt. A. Bouchard.....Engr. Frank Killian

Fitzpatrick, Joseph (See Fleet No. 191)

120 Fitzsimons & Connell Dredge & Dock Co., 10 South LaSalle St., Chicago, Ill.
 (Owner and Operator)

Tug Charles J. Connell.....Capt. R. F. Harman.....Engr. L. Austin
 Tug LaSalleCapt. D. Barrett.....Engr. J. Lyons
 Tug TacomaCapt. R. D. Myers.....Engr. A. Anderson

121 Fix Bros., 1826 Niagara St., Buffalo, N. Y. (Owner and Operator)

Str. FranklinCapt.Engr.
 Str. GlennCapt.Engr.
 Str. Plow Boy.....Capt.Engr.
 Tug Clarence Fix.....Capt.Engr.
 Tug Henry Koerber, Jr.....Capt.Engr.
 Tug W. D. Krapp.....Capt.Engr.

Fontana Steamship Co. (See Fleet No. 68)

122 Ford Motor Company, Detroit, Mich. (Owner and Operator)

M. S. Benson Ford.....Capt. A. Pedersen.....Engr. F. H. Bernard
 Tug ButtercupCapt. J. Pearce.....Engr. R. E. Currie
 M. S. Henry Ford II.....Capt. E. Innis.....Engr. G. R. Murray
 Tug BarralltonCapt. N. Gonyau.....Engr. N. E. Beard

Tug D. HebardCapt. B. Nelsen.....Engr. Geo. Glover
 Tug HumrickCapt. D. D. Brown.....Engr. C. J. Adamson
 Tug J. C. Meade.....Capt. D. Cody.....Engr. Geo. Pedersen
 Bge. Lake Allen.....(Appointments not available)
 Bge. Lake Crystal.....(Appointments not available)
 Bge. Lake Hemlock.....(Appointments not available)
 Bge. Lake Kytte.....(Appointments not available)
 Bge. Lake Louise.....(Appointments not available)

123 Foss, Estate of Edgar B., Bay City, Mich. (Owner and Operator)
 (Detroit Trust Co.) (Administrator)

Bge. Clarence J. Fillmore...Capt. John Haggerty.....

Franklin Steamship Co. (See Fleet No. 273)

124 Fraser, John S. Wallaceburg, Ont. (Operator)

(Wallaceburg Sand & Gravel Co., Ltd.) (Owner) Allan K. Fraser.

Tug Annette Fraser.....Capt.Engr.
 Tug Jean Fraser.....Capt. Elmer Winter.....Engr. Nelson Harris
 Sand Barge Rose Burgess..Capt. John McCallum.....

125 Fraser, Capt. S. Kenneth, Towing & Wrecking, Amherstburg, Ont.
 (Owner and Operator)

Tug Betty D.....Capt. S. K. Fraser.....Engr. W. C. Koake

126 Frontenac Dredging Co., Kingston, Ont. (Owner and Operator)

Walter Smith, Superintendent.

Tug William Davis.....Capt.Engr. Percy Haller
 Tug ElertCapt.Engr.

127 **Garriock, Wm., Port Arthur, Ont. (Owner and Operator)**
 Tug Bessie MCapt. Wm. GarriockEngr.

Gartland Steamship Co. (See Fleet No. 368)

128 **Gatfield & Maisey, Sandwich, Ont. (Owner and Operator)**
 Str. Col. Lusk.....Capt. I. Spitlog.....Engr. B. Line

129 **General Transit Co., 1812 Union Trust Bldg., Cleveland, Ohio**
 (Owner and Operator) C. W. Bryson, Manager.
 Str. Thomas Maytham.....Capt. Ed. Recor.....Engr. M. R. Williams
 Bge. TyroneCapt. T. K. Woodward.....Engr. A. V. Anderson

130 **Georgian Bay Tourist Co. of Midland, Ltd., Wharf, Midland, Ont.**
 (Owner and Operator)
 Str. Midland City.....Capt.Engr. William Carefoot
 Str. City of Dover.....Capt. George Moreau.....Engr. Andrew Moreau
 Str. Yacht Tenno.....Capt.Engr.
 Str. WaterbusCapt. D. McGrattan.....Engr.

131 **Gerkin, Howard, 39 Lisbon St., Buffalo, N. Y. (Owner and Operator)**
 Str. NiagaraCapt. Thomas Neffanson.....Engr. George Baron

132 **Gilbert, John H., Sandusky, Ohio (Owner and Operator)**
 Diesel Tug Tourist.....Capt. Frank Kropp.....Engr. John H. Gilbert

133 **Gillen, Edward E., Towing Co., Milwaukee, Wis. (Owner and Operator)**
 Tug Edward E. Gillen.....(Appointments not available)
 Tug Knight Templar.....(Appointments not available)
 G. L. Earl A.....(Appointments not available)
 Semi Diesel Ernest E.
 Beauvais(Appointments not available)

82

134 **Gleason, F. D., Coal Co., Detroit, Mich. (Owner and Operator)**
 J. Armand Pearson, Fleet Manager
 Str. Harlow(Appointments not available)
 Str. Jay A. Pearson.....(Appointments not available)
 Str. TampicoCapt. Peter J. Cullon.....Engr. F. Emig
 Str. Usona(Appointments not available)
 Tug 3rd Michigan.....(Appointments not available)

Globe Steamship Co. (See Fleet No. 381)

135 **Glover, Nettie, 12365 Wyoming Ave., Detroit, Mich. (Owner and Operator)**
 Bge. Thomas Gawn.....Capt.Engr.

136 **Goodrich Transit Co., Navy Pier, Chicago, Ill. (Owner and Operator)**
 Capt. W. E. Franklin, Superintendent, Joseph Peroutka, Chief Engineer.
 Str. AlabamaCapt. G. E. Stufflebeam.....Engr. T. C. Green
 Str. CarolinaCapt. Con McCauley.....Engr. J. P. Breuer
 Str. City of Benton Harbor (Not in commission)
 Str. City of Grand Rapids..Capt. M. F. Morgan.....Engr. Byron Beerman
 Str. City of Holland.....Capt. D. A. McDonald.....Engr. John Golden
 Str. City of Saugatuck.....Capt. Oscar Bjork.....Engr. Walter Carlson
 Str. City of St. Joseph.....(Not in commission)
 Str. Christopher Columbus..Capt. Chas. E. Moody.....Engr. J. W. Schneider
 Str. IllinoisCapt. J. C. Crawford.....Engr. Oscar Dahlgren
 Str. IndianaCapt. Jos. Carrigan.....Engr. J. M. Buschmann
 Str. Theodore Roosevelt.....Capt. M. D. Mackey.....Engr. G. E. Suckow
 Str. WisconsinCapt. D. H. Morrison.....Engr. Thos. Fitzpatrick
 Tug ArcticCapt. Wm. A. Clark.....Engr. John Meyer

83

137 **Graham & Wilkinson, Little Current, Ont., Canada (Operator)**

(R. R. Graham) (Owner)

Tug Helen S.....'apt. Clifford Bradley.....Engr. Wm. Terry

138 **Grand Trunk Milwaukee Car Ferry Co. (Owner and Operator)**

Room 402, Chamber of Commerce Bldg., Milwaukee, Wis. C. E. McLaren, Manager.

C. F. Grand Haven.....Capt. Engr.
C. F. Grand Rapids.....Capt. Engr.
C. F. MadisonCapt. Engr.
C. F. MilwaukeeCapt. Engr.

139 **Grand Trunk Railway System, Windsor, Ont. (Operator)**

(Canadian National Railways) (Owner) R. Aikin, Superintendent of Ferries.

C. F. HuronCapt. Michael Bansette.....Engr. William Belsom
C. F. LandsdowneCapt. Frank Bansette.....Engr. John Matheson

140 **Gravel Products Corp., 78 Perry St., Buffalo, N. Y. (Owner and Operator)**

Str. NiagaraCapt. Thos. N. Heffernan....Engr. George Bacon
Bge. Crete(Appointments not available)

141 **Great Lakes Dredge & Dock Co., 104 S. Michigan Ave., Chicago, Ill. (Owner and Operator) William Murphy, General Superintendent.**

(The engineers and captains are not regularly assigned to any particular tug and are shifted from one vessel to another in accordance with the demands of their operating conditions.)

Tug Badger State.....Tug Martin Hausler, Jr....Tug James J. Murray.....
Tug Walter Cahill.....Tug William H. Kinch..... (nee Walter F. Mattich)
Tug CalumetTug LeeTug Fred E. Richards.....

84

Tug James H. Cassidy.....Tug William A. Lydon.....Tug L. P. Smith.....
Tug E. C. Dempsey.....Tug MarionTug Roger C. Sullivan.....
Tug James Edward.....Tug Martha C.....Tug Harry C. Wild.....
Tug Effie L.....Tug Mary C.....Tug Charles E. Williams....
Tug Andrew H. Green.....Tug Oscar F. Mayer.....Tug John R. Williams.....
Tug HassayampaTug H. A. Meldrum.....

142 **Great Lakes Dredging & Contracting Co., Ltd., Port Arthur, Ont. (Owner and Operator) J. C. Fitzgerald.**

Tug Curlew(Appointments not available)
Tug Joe Dudley.....(Appointments not available)
Tug Thomas Fisher.....(Appointments not available)
Tug Minnie W.....(Appointments not available)
Tug J. D. Morrison.....(Appointments not available)
Tug Edward C. Whalen.....(Appointments not available)

85

143 **Great Lakes Engineering Works, River Rouge, Detroit, Mich. (Owner and Operator)**

Tug EcorseCapt. Paul Kohn.....Engr. Ira Melick

144 **Great Lakes Steamship Co., Inc., 1548 Rockefeller Bldg., Cleveland, Ohio (Owner and Operator) George F. Lynn, Fleet Engineer.**

Str. Belgium(Appointments not available)
Str. John B. Cowle.....Capt. E. E. Carleton.....Engr. Hugh Gangwish
Str. DenmarkCapt. E. M. Warwick.....Engr. James C. Browne
Str. John Dunn, Jr.....Capt. George W. Pierce.....Engr. H. Otis Smith
Str. J. F. Durston.....Capt. Charles Caughell.....Engr. Henry Cowan
Str. FinlandCapt. F. B. Parsons.....Engr. Oscar Schnyder

Str. Charles Hubbard.....	Capt. W. C. Butts.....	Engr. J. R. Goodrich
Str. George B. Leonard.....	Capt. John W. Upledger.....	Engr. Fred Anton
Str. A. E. Nettleton.....	Capt. James B. Watts.....	Engr. Burt Beauchamp
Str. Norway	Capt. J. H. Driscoll.....	Engr. T. J. O'Connor
Str. William Nottingham....	Capt. George R. Manuel.....	Engr. Thomas Greenlaw
Str. B. Lyman Smith	Capt. J. A. Edwards.....	Engr. J. J. Roquett
Str. Hurlbut W. Smith	Capt. S. A. Solway.....	Engr. Charles R. Blanchard
Str. Lyman C. Smith	Capt. Pierre Bouille.....	Engr. Dan McDonald
Str. Monroe C. Smith.....	Capt. Charles Gonyaw.....	Engr. Lester Pray
Str. Wilbert L. Smith.....	Capt. N. B. Roach.....	Engr.
Str. Sweden	Capt. H. L. Stewart.....	Engr. Wm. Murphy
Str. Smith Thompson.....	Capt. Howard Geel.....	Engr. B. A. Ray
Str. H. S. Wilkinson.....	Capt. R. J. Lyons.....	Engr. John Brunner

145 Great Lakes Towing Co., Cleveland, Ohio (Owner and Operator)

The Great Lakes Towing Co. have never published the names of the captains and engineers of the tugs for the reason that it is not practical to do so.

In the first place, these appointments are made by the local managers at their respective ports. In addition most of their tugs are double crewed and for that reason they each have two captains and two chief engineers.

Tug Alabama	Tug Illinois	Tug E. M. Pierce.....
Tug Alpena	Tug Indiana	Tug Racine
Tug America	Tug Iowa	Tug R. P. Reidenbach.....
Tug Ashtabula	Tug Kansas	Tug L. C. Sabin.....
Tug Delaware	Tug Kenosha	Tug Sandusky
Tug Buffalo	Tug Lorain	Tug James R. Sinclair.....
Tug California	Tug Louisiana	Tug Tennessee

Connecticut	Tug T. C. Lutz.....	Tug Texas
Colorado	Tug Maine	Tug Toledo
Tug Detroit	Tug Maryland	Tug John M. Truby.....
Tug Dunkirk	Massachusetts	Tug Vermont
Tug Fairport	Tug W. L. Mercereau.....	Tug Virginia
Tug Favorite	Tug Michigan	Tug Washington
Tug Wm. A. Field.....	Tug Minnesota	Tug Waukegan
Tug Florida	Tug Mississippi	Tug Wisconsin
Tug Frank W.....	Tug Missouri	Tug Yale
Tug Gary	Tug New Jersey.....	Lighter T. F. Newman.....
Tug Georgia	Tug New York.....	Lighter Pontoon
Tug Q. A. Gilmore.....	Tug North Harbor.....	Lighter Reliance
Tug Abner C. Harding.....	Tug Ohio	Lighter Relief
Tug Harvard	Tug Oregon	Lighter Rescue.....
Tug Huron	Tug Pennsylvania	

146 Great Lakes Transit Corp., 223 Erie St., P. O. Box 987, Buffalo, N. Y. (Owner and Operator)

Str. W. W. Atterbury	Capt. J. J. Lehan.....	Engr. Wm. Wilson
Str. Ralph Budd.....	Capt. Dugald McLeod.....	Engr. C. L. Murray
Str. Edward Chambers.....	Capt. J. H. Gallagher.....	Engr. Alphonse Liston
(nee North Sea)		
Str. Chicago	Capt. P. C. Farrell.....	Engr. Edward Clarke
Str. W. J. Conners.....	Capt. Thos. Stevenson.....	Engr. John O'Neil
Str. Delos W. Cooke.....	Capt. John McGillivray.....	Engr. M. J. Reagan
Str. P. E. Crowley.....	Capt. W. H. Stevenson.....	Engr. R. C. Stewart
Str. J. M. Davis.....	Capt. Paul J. Healy.....	Engr. Geo. Broad, Jr.
Str. G. D. Dixon.....	Capt. Paul Ebisch.....	Engr. John Lynch

Str. Charles Donnelly.....	Capt. Wm. S. MacDonald....	Engr. P. O. Murphy
Str. Duluth	Capt. John Kennedy.....	Engr. John Rainey
Str. J. E. Gorman.....	Capt. Wm. B. Holme.....	Engr. A. B. McArthur
Str. C. T. Jaffray.....	Capt. Alex McKenzie.....	Engr. Wm. W. Shaw
Str. Juniata	Capt. A. J. McPherson...	Engr. C. J. Wilson
Str. Edward E. Loomis.....	Capt. C. H. Murphy....	Engr. John Metke
Str. Milwaukee	(Appointments not available)	
Str. North Star.....	Capt. R. B. Wilkinson.....	Engr. Chas. Wesley
Str. Octorara	Capt. S. R. Jones.....	Engr. Frank Miller
Str. Fred W. Sargent.....	Capt. J. D. Greene	Engr. J. T. Graham
(nee Delaware)		
Str. Alfred H. Smith.....	Capt. A. W. Hayden...	Engr. J. E. Laney
Str. Tionesta	Capt. John Doherty.....	Engr. R. J. Keefe
Str. F. D. Underwood.....	(Appointments not available)	
Str. Utica	Capt. Albert Goodberry....	Engr. E. G. O'Connell
Str. Daniel Willard.....	Capt. J. C. Clarke.....	Engr. J. S. Eckert
Lighter Black Diamond...	Capt. Joseph Donahue.....	Engr. J. Sullivan

ENGINEERING

147 Greiling Engineering Co., Green Bay, Wis. (Owner and Operator)

(The captains and engineers vary for the vessels listed below)

Tug Fred C. Greiling.....	Capt.	Engr.
Tug Satisfaction	Capt.	Engr.
Tub Bob Teed.....	Capt.	Engr.

148 Gunderson Brothers, Sheboygan, Wis. (Owner and Operator)

Tug Henry F. Brower.....	Capt. Theo. Gunderson.....	Engr. George Russell
--------------------------	----------------------------	----------------------

149 Hackett Steamboat Co., Quebec, Que. (Owner and Operator)

Tug C. A. B.	Capt. D. Kovingtons.....	Engr. A. Lamontagne
Tug M. E. Hackett	Capt. Augure Desclene...	Engr. Ernest Boivers
Tug Willie H.	Capt. Wm. Allison.....	Engr. N. Lamontagne

150 Hall, George Corp., Ogdensburg, N. Y. (Owner and Operator)

Str. Adrian Iselin.....	Capt. H. M. Russell.....	Engr. Wm. Burtch
Str. Harvey J. Kendall.....	Capt. Thomas Burns....	Engr. E. L. Hyatt
Str. L. W. Robinson.....	Capt. Harold Brosnan.....	Engr. Wm. Thomson
Bge. W. A. Sherman..	(Not in commission)	

151 Hammermill Paper Co., Erie, Pa. (Owner and Operator) E. L. Heal.

Str. C. W. Jacob.....	Capt.	Engr.
-----------------------	------------	------------

152 Hanna, M. A. Co., The, Agents, Cleveland, Ohio (Operator)

(The Calumet Transportation Co.) (Owner) Douglas Brews, Port Engineer.

Str. R. L. Agassiz.....	Capt. George Levis	Engr. Wm. R. Stewart
Str. Edwin N. Saunders...	Capt. S. Sexsmith.....	Engr. R. M. Akerly
Str. Quincy A. Shaw.....	Capt. F. A. Colson.....	Engr. P. J. Ahern
Str. J. J. Turner.....	Capt. A. H. Hartman.....	Engr. John Watt
Str. Edward A. Uhrig.....	Capt. M. M. Stewart.....	Engr. S. E. Atkinson

153 Hanna, M. A., Co., The, Agents, Cleveland, Ohio (Operator)

(The Donner Steamship Co.) (Owner) Douglas Brews, Port Engineer.

Str. H. F. Black.....	Capt. H. Wendorf.....	Engr. E. W. Frye
-----------------------	-----------------------	------------------

154 Hanna, M. A., Co., The, Agents, Cleveland, Ohio (Operator)

(The Eastern Steamship Co.) (Owner) Douglas Brews, Port Engineer.

Str. Joseph Wood.....	Capt. G. C. Hibbard.....	Engr. F. J. Auttersen
-----------------------	--------------------------	-----------------------

155 **Hanna, M. A., Co., The, Agents, Cleveland, Ohio (Operator)**
 (The La Belle Steamship Co.) (Owner) Douglas Brews, Port Engineer.
 Str. La Belle.....Capt. J. M. Brines.....Engr. R. H. Shinsky

156 **Hanna, M. A., Co., The, Agents, Cleveland, Ohio (Operator)**
 (Mahoning Steamship Co.) (Owner) Douglas Brews, Port Engineer.
 Str. W. H. Donner.....Capt. C. C. Hanley.....Engr. H. F. Stearns
 Str. L. C. Hanna.....Capt. F. DesJardins.....Engr. J. A. McCarron
 Str. Powell Stackhouse.....Capt. V. L. Hosner.....Engr. Wm. J. Baird

157 **Hanna, M. A. Co., The, Agents, Cleveland, Ohio (Operator)**
 (The Producers Steamship Co.) (Owner) Douglas Brews, Port Engineer.
 Str. W. A. Amberg.....Capt. J. T. Autterson.....Engr. A. Farquhar
 Str. L. W. Hill.....Capt. G. D. Tulian.....Engr. A. Robertson
 Str. C. A. Thompson.....Capt. Wm. Langell.....Engr. Frank L. Saunders

158 **Hanna, M. A., Co., The, Agents, Cleveland, Ohio (Operator)**
 (The Virginia Steamship Co.) (Owner) Douglas Brews, Port Engineer.
 Str. W. D. Crawford.....Capt. John R. Hesson.....Engr. John Summerville

159 **Harbor Commissioners of Montreal, Montreal, Que. (Owner and Operator)**
 J. F. Symons, Harbor Master, G. R. Dalkin, Supt. Engr. of Fleet.
 Str. Bethalma (Appointments not available)
 Tug Aberdeen (Appointments not available)
 Tug Sir Hugh Allan (Appointments not available)
 Tug Robert McKay..... (Appointments not available)
 Tug Passepartout (Appointments not available)
 Tug St. Peter..... (Appointments not available)
 Tug John Young..... (Appointments not available)
 Barge Ethel (Appointments not available)

160 **Harrigan, John J., Port Dalhousie, Ont. (Owner and Operator)**
 Tug Austin H.....Capt. Wm. Minor.....Engr. J. Morgan
 Tug J. R. Binning.....Capt. Allan Howe.....Engr. C. Kenney
 Tug Escort Capt. Wm. Rooney.....Engr. J. Anderson
 Tug Ethel (Appointments not available)
 Tug Joe Goodwin.....Capt. Wm. McLaren.....Engr. W. Howe

161 **Harris, Geo. P., Ltd., Ottawa, Ont. (Operator)**
 (Empress Navigation Co., Ltd.) (Owner)
 Str. Empress Capt. E. P. Shepherd.....Engr. Armand Grenier

162 **Harrison, John & Sons Co., Ltd., 1417 Second Ave., W., Owen Sound, Ont. (Owner and Operator)**
 Tug HarrisonCapt. George Waugh.....Engr. George Robinson
 Tug PinolaCapt. Andrew EllisEngr. Secord Cole
 Lighter Davidson..... (Appointment no avail- Engr. Thos. Mock
 able)

163 **Hawkesburg Lumber Co., 134 Wellington St., Ottawa, Ont. (Owner and Operator)**
 Tug Nathalie R.....Capt. Joseph Seguin.....Engr. Paul Turpin

164 **Henning, A., Pt. Burwell, Ont. (Owner and Operator)**
 Tug Brown Brothers.....Capt. A. Henning.....Engr. M. Bates

165 **Hettler, Herman H., Lumber Co., 2601 Elston Ave., Chicago, Ill. (Owner and Operator)**

Str. T. S. Christie.....Capt. Hans Hansen.....Engr. James Curry

166 **Hill-White Transit Co., Green Bay, Wis. (Owner and Operator)**
 M. S. Marold IICapt. L. L. Hill.....Engr. L. A. Hill

167 **Hinckley, A. R., Co., Oswego, N. Y. (Owner and Operator)**
 Str. HinckleyCapt.Engr.
 Str. Isabella H.....Capt.Engr.
 Str. PentlandCapt.Engr.
 Tug NightingaleCapt.Engr.
 Bge. F. A. Georger.....Capt.Engr.
 168 **Holcomb Navigation Co., Cardinal, Ont. (Owner and Operator)**
 Str. R. T. Holcomb.....Capt. L. Orr.....Engr. O. Toupin
 169 **Holler, J. W., Inc., Fort Edward, N. Y. (Owner and Operator)**
 Tug Thomas Miller, Jr.....Capt.Engr.
 170 **Holmes, W. E. (M. O.) 175 W. Jackson Blvd., Chicago, Ill. (Operator)**
 (Central Transportation Co.) (Owner)
 Str. MuellerCapt. L. F. StrahanEngr. John Jordan
 Bge. Robert L. FreyerCapt. Gus MeyerEngr.
 171 **W. W. Holmes, Redwood, N. Y. (Owner and Operator)**
 Str. RiversideCapt. Sam Bain.....Engr. Chas. Wood
 172 **Homegardner Sand Co., Sandusky, Ohio (Owner and Operator)**
 Str. Mary H.....Capt. John E. Hess.....Engr. Pete Peterson
 173 **Huron Contracting Co., Alpena, Mich. (Owner and Operator)**
 Tug CharlotteCapt.Engr.
 174 **Huron Transportation Co., 1325 Ford Bldg., Detroit, Mich.**
 (Owner and Operator)
 P. H. Townsend, Port Captain.
 W. W. England, Superintendent Engineer.
 Str. John W. BoardmanCapt. Donald McLachlan.....Engr. James Oliver

92

Str. S. T. CrapoCapt. W. H. BoothEngr. Charles J. Fritz
 Str. Samuel Mitchell.....(No appointment)Engr. Martin Mitchell
 175 **Hutchinson & Co., Mgrs., 1508 Rockefeller Bldg., Cleveland, Ohio (Operator)**
 (Inland Steamship Co.) (Owner)
 Anton Rud, Fleet Engineer.
 Str. Joseph Block.....Capt. A. A. Clarke.....Engr. W. B. Rowe
 Str. L. E. Block.....Capt. Jos. Matthews.....Engr. Frank N. Lang
 Str. N. F. Leopold.....Capt. F. A. Tomlin.....Engr. Edwin Espeland
 176 **Hutchinson & Co., Mgrs., 1508 Rockefeller Bldg., Cleveland, Ohio (Operator)**
 (Pioneer Steamship Co.) (Owner)
 Anton Rud, Fleet Engineer.
 Str. AmazonCapt. H. P. VanVelzen.....Engr. E. S. Stoddard
 Str. A. A. Augustus.....Capt. J. M. Johnson.....Engr. Albert Holl
 Str. Frank Billings.....Capt. F. B. Cody.....Engr. Alex Kronberg
 Str. Philip D. Block.....Capt. W. P. Benham.....Engr. S. H. Rowswell
 Str. Joseph G. Butler, Jr.....Capt. John A. Logan.....Engr. Aloysius A. Wolf
 Str. W. D. Calverley, Jr.....Capt. John Rutledge.....Engr. John Paytosh
 Str. Chippewa(Appointments not available)
 Str. S. B. CoolidgeCapt. M. J. JohnsonEngr. E. P. Moens
 Str. James E. Ferris.....Capt. W. A. Deland.....Engr. John Linden
 Str. Charles L. Hutchinson ..Capt. James H. Smith.....Engr. Geo. Blauvelt
 Str. W. H. McGean.....Capt. James F. Goodwin.....Engr. W. L. Smith
 Str. Price McKinney.....Capt. E. C. Van Patten.....Engr. Lloyd Backie
 Str. John S. ManuelCapt. H. W. Frilay.....Engr. Claren H. Schunne-
 son
 Str. Martin MullenCapt. E. P. Maxim.....Engr. Peter B. Johnson

93

Str. William A. Paine.....Capt. Fred Smith.....Engr. Oliver T. Biddle
 Str. John StantonCapt. Theo. A. Johnson.....Engr. Hugh McLaughlin
 Str. J. J. SullivanCapt. Sevren O. Nelssen.....Engr. H. T. Landers
 Str. David P. Thompson.....Capt. A. J. Munroe.....Engr. F. W. Wolfe
 Str. G. A. Tomlinson.....Capt. H. J. Scheible.....Engr. Geo. Schroder
 Str. James P. Walsh.....Capt. Harold A. Johnson.....Engr. Ernest Fournier

177 **Illinois Dredge & Shipping Co., 39 South La Salle St., Chicago, Ill.**
 (Owner and Operator)

Str. BrazilCapt. Henry N. YoungEngr. William Dueno
 178 **Illinois Dredge & Shipping Co., 39 South La Salle St., Chicago, Ill. (Operator)**
 (Nassau Ship & Dredge Co.) (Owner)

Str. NassauCapt. John Messner.....Engr. H. Evans
 179 **Imperial Oil, Ltd., 56 Church St., Toronto, Ont. (Owner and Operator)**
 W. B. Ellsworth, Manager.
 J. E. Langdon, Superintending Engineer.

94

Str. ImperoyalCapt. R. LaingEngr. R. D. Knox
 Str. IocoliteCapt. O. D. Williamson.....Engr. F. Pringle
 Str. RoyaliteCapt. W. J. MacDonald.....Engr. J. Bulmer
 Str. SarnoliteCapt. H. DavidsonEngr. E. W. Sparling
 Str. WindsoliteCapt. H. C. MimmsEngr. H. R. Welch
 Bge. I. O. Ltd. No. 6.....Capt. J. R. Anderson.....Engr.

Inland Steamship Co. (See Fleet No. 175)
 Interlake Steamship Co. (See Fleet No. 295)

180 **International Harvester Co., 606 South Michigan Ave., Chicago, Ill.**
 (Owner and Operator)

Str. The HarvesterCapt. Wells EgerEngr. E. T. Everell

181 **International Transit Co., Sault Ste. Marie, Ont. (Operator)**
 (St. Marys River Construction Co.) (Owner)
 P. Martin

M. S. AgomingCapt. M. GriffithEngr. P. Martin

182 **International Waterways Navigation, Ltd., 33 St. Nicholas St., Montreal, Que.**
 (Owner and Operator)

Str. AragonCapt. M. Heffernan.....Engr. Willard Chipman
 Str. BelvoirCapt. F. M. Heffernan.....Engr. H. W. Johnston
 Str. Donald StewartCapt. H. Finn.....Engr. W. Keith

Inter Ocean Steamship Co. (See Fleet No. 382)

183 **Interstate Steamship Co., 815 Rockefeller Bldg., Cleveland, Ohio**
 (Owner and Operator)

R. W. England, Marine Superintendent.

Str. B. F. Jones.....Capt. Geo. W. Swails.....Eng. C. L. Irish
 Str. Willis L. King.....Capt. F. N. WattsEngr. Ed. Reilly
 Str. James Laughlin.....Capt. F. H. ReidEngr. W. H. Ballard
 Str. Thomas WaltersCapt. M. G. AllanEngr. Wm. Sicken

Iroquois Steamship Co. (See Fleet No. 31)

Island Transportation Co. (See Fleet No. 191)

184 **Jenkins Steamship Co., 1912 Union Trust Bldg., Cleveland, Ohio**
 (Owner and Operator)

F. W. Green, Port Captain.

Str. Wm. F. Fitch.....Capt. H. W. Emigh.....Engr. Harold Comstock
 Str. Charles O. Jenkins.....Capt. W. M. Anderson.....Engr. G. H. Miller

95

193 Kelly, John T., Manager, 1202-4 Hanna Bldg., Cleveland, Ohio (Operator)
(Columbia Steamship Co.) (Owner)

Str. Joseph H. Frantz	Capt. O. A. Gentz	Engr. Harry Roberts
Str. Harvey D. Goulder	Capt. Alex McDonald	Engr. Matt Flagstad
Str. Howard M. Hanna, Jr.	Capt. Carl Carlsen	Engr. A. E. Bates
Str. C. Russell Hubbard	Capt. Charles Ernest	Engr. C. W. Gustin
Str. William Livingstone.....	Capt. Frank Blacklock	Engr. Oscar Anderson
Str. Leonard B. Miller	Capt. Leonard B. Miller	Engr. T. G. Simmons
Str. David Z. Norton	Capt. Joseph S. Moran	Engr. James A. Southgate
Str. W. C. Richardson	Capt. R. J. Reid	Engr. George Marcous
Str. William F. Stifel	Capt. Phil Lennon	Engr. James E. Eustice
Str. John A. Topping	Capt. Wm. Hagan	Engr. Chris Johnson

194 Keystone Fish Co., Erie, Pa. (Owner and Operator)

Tug Atlas	Capt. Arthur Rudd	Engr. J. Dewey
Tug Jupiter	Capt. Jno. Regnor	Engr. F. Vian
Tug Uranus	Capt. Chas. Zuern	Engr. Harry Austin
Tug Venus	Capt. Chas. Boles	Engr. Lee Simmons

195 Keystone Transports, Ltd., Room 317, 83 Craig St., West, Montreal, Que.
(Owner and Operator)

John Waller, Operating Superintendent.

Str. Keybar	Capt. W. V. Smith	Engr. R. Garriock
Str. Keybell	Capt. W. A. Davis	Engr. R. J. Muchmore
Str. Keynor	Capt. Geo. Brown	Engr. J. Boak
Str. Keyport	Capt. C. J. Kenney	Engr. Lars Nordnes
Str. Keystate	Capt. Leo Beaupre	Engr. David Annand

Str. Keyvive	Capt. E. J. Smith	Engr. Geo. Baker
Str. Keywest	Capt. S. G. Williamson	Engr. Alex Horton

196 Kilmer & Barber, Contractors, 10 Adelaide St., East, Toronto, Ont.
(Owner and Operator)

Tug Erl King (Appointments not available)

197 Kingston Navigation Co., Ltd., Foot of Brock St., Kingston, Ont.
(Owner and Operator)

Str. Brockville	Capt. Gilbert Arthur	Engr. Ross Leslie
-----------------------	----------------------------	-------------------

198 Kinney Steamship Co., 1523 Rockefeller Bldg., Cleveland, Ohio
(Owner and Operator)

Str. J. S. Ashley	Capt. Ivan Kennedy	Engr. John Norton
Str. R. L. Ireland	Capt. Lew Morrow	Engr. Thos. Brownlee
Str. A. T. Kinney	Capt. M. G. McIntosh	Engr. E. A. Gustin
Str. A. S. Upson	Capt. Arthur F. Mason	Engr. Clark Swartz
Str. Robert B. Wallace	Capt. J. W. Ehrhart	Engr. Walter Declute

Kinsman Transit Co. (See Fleet No. 365)

The Kishman Fish Co. (See Fleet No. 238)

199 Koenig Coal & Supply Co., 1480 Gratiot, Detroit, Mich. (Owner and Operator)
 Str. Peter Koenig

200 Kolbe Fisheries Co., Erie, Pa. (Owner and Operator)
 I. H. Kolbe, Manager.

Tug Charles L.	Capt. Dan Regan	Engr. J. Nolan
Tug Isabelle	Capt. John Maher	Engr. Wm. Michels
Tug Louise	Capt. J. Ferguson	Engr. A. Barry
Tug Seabird	Capt. H. Morewood	Engr. S. Hornic

201 **Kreetan Co., Johnswood, Mich. (Owner and Operator)**
 Tug Silver Spray (Not in commission)
 Gas Kreetan (No regular crew)

202 **Kreetan Co., Tonowanda, N. Y. (Owner and Operator)**
 Str. Mathew Wilson Capt. Engr.

203 **LaBeau Wrecking Co., Toledo, Ohio (Owner and Operator)**
 La Belle Steamship Co., The (See Fleet No. 155)
 Tug James E. Brailey (Not in commission)

204 **Lake Champlain Transportation Co., Whitehall, N. Y. (Owner and Operator)**
 F. A. Moore, Port Captain.
 G. R. Ernest, Engineer.

Str. Robert H. Cook Capt. V. H. Fontaine Engr. Jas. Arnette
 Str. Defender Capt. Edmund Menard Engr. Henry Jarnis
 Str. Dorothy Capt. Fred Shovah Engr. Peter Matte
 Str. Fort Ann Capt. Frank Moore Engr. Fred Yule
 Str. Fort Edward Capt. Mike Lafontaine Engr. Frank Story
 Str. Stillwater Capt. Wm. Whalen Engr. Jas. Arnette
 Str. Triton Capt. Frank Moore Engr. Chas. Shimier
 Str. Waterford Capt. Leo Fontaine Engr. M. Gordon
 Str. Whitehall Capt. John Blair Engr. Fred Yule

205 **Lake Erie Coal Co., Ltd., Walkerville, Ont. (Owner and Operator)**
 Str. Alexander Leslie Capt. Jas. Gunn Engr. John Smith
 (nee H. A. Rock)

206 **Lake Erie Navigation Co., Ltd., Walkerville, Ont. (Operator)**
 (Marquette & Bessemer Dock & Navigation Co.) (Owner)
 Str. Marquette & Bessemer
 No. 1 Capt. W. R. Neal Engr. Ellis Solway

207 **Lake Ports Shipping & Navigation Co., 1013 Dime Bank Bldg., Detroit Mich.**
 (Owner and Operator) W. E. Richey, Vice President and General Manager
 Str. Henry Cort Capt. Arthur A. Kiddle..... Engr. H. W. Shaw

208 **Lake Sand Corp., 228 No. La Salle St., Chicago, Ill. (Owner and Operator)**
 Wm. Hausler. C. C. De Pew, Manager.

Str. Gilbert Capt. C. D. Brown Engr. F. Benash

209 **Lakes & St. Lawrence Navigation Co., Ltd., Cardinal, Ont.**
 (Owner and Operator)

Str. Casco Capt. W. J. Mills Engr. S. E. Moore

210 **Lake Superior Paper Co., Ltd., Sault Ste. Marie, Ont. (Owner and Operator)**
 (Spanish River Pulp & Paper Mills) (Owner)
 Thos. Ganley, Superintending Engineer.

Tug Commodore Capt. Joseph Griffith Engr. N. Girard
 Tug George Emerson Capt. A. LaHaye Engr. P. Lesage
 Tug Gargantua Capt. D. A. Williams Engr. Jno. Urquhart
 Tug G. R. Gray Capt. J. P. Ramsay Engr. A. Lewis
 Tug Puckasaw Capt. A. Ostrom Engr. W. Archibald
 Tug Reliance Capt. W. Alexander Engr. Thos Riley
 Str. Wahcondah Capt. F. G. Moles Engr. W. Dungan

Langell Transportation Co. (See Fleet No. 245)

211 **Larsen, Capt. J. L., 201 Tuscola Road, Bay City, Mich. (Operator)**
 (Larsen & Olsen) (Owner)
 Bge. C. E. RedfernCapt. J. L. LarsenEngr. A. N. Scofield
Laurentide Co., Ltd., (See Fleet No. 251)

212 **Lehigh Valley Coal Sales Co., Buffalo, N. Y. (Operator)**
 (Lehigh Valley Coal Sales Co., New York City) (Owner)
 William M. Barr, Superintendent.

Str. BataviaCapt. Herman HillstrandEngr. Frank Donovan
Les Chantiers Manseau (See Fleet No. 230)

213 **Levis Ferry Co., Ltd., Levis, Que. (Owner and Operator)**
 A. Chabot, Port Captain.
 Pierre Plant, Superintending Engineer.

Str. BienvilleCapt. Octave FortierEngr. Wilfrid Derrochers
 (nee McKie)

Str. ColbertCapt. Ulderic LenveuxEngr. Arthur Begin
 (nee Baxter)

Str. ColombCapt. Alphonse ForguesEngr. Napoleon Lamothe

Str. LauzonCapt.Engr.

Str. PlessisCapt. Cyrille MartelEngr. Severin Beaudet

214 **Little Falls Engineering Equipment, Inc., Little Falls, N. Y.**
(Owner and Operator)

Tug BaileyCapt.Engr.

Tug Alfred J. MurrayCapt.Engr.

Tug PandoraCapt.Engr.

215 **Lockhart, D. O., 72 Pearl St., Buffalo, N. Y. (Owner and Operator)**
 Str. SachemCapt.Engr.

216 **Lutz, Edward, & Sons, Michigan City, Ind. (Owner and Operator)**
 Tug LuebkeCapt. E. LutzEngr. A. Lutz

217 **McConville, Arthur F., Ogdensburg, N. Y. (Owner and Operator)**
 Bge. New Dominion(Not in commission)

218 **MacDonald, Capt. Alex, 71 West 3rd St., Oswego, N. Y. (Owner and Operator)**
 Str. Louis PahlowCapt. A. MacDonaldEngr. G. E. Marshall

219 **McFadden, J. J., Ltd., Blind River, Ont. (Operator)**
 (J. J. McFadden, Ltd., Spragge, Ont.) (Owner)

Tug John R. Stover

220 **McGrath, Daniel, 58 Triller, Toronto, Ont. (Owner and Operator)**
 Tug StrathbungoCapt. D. J. McGrathEngr. George Russell

221 **McLean & Sons, A. B., 123 Spring St., Sault Ste. Marie, Ont.**
(Owner and Operator) R. A. McLean

Tug HalladayCapt. L. ShipmanEngr. William Beron

Tug Charles Riter(Not in commission)

Tug SpraggeCapt. Angus MathesonEngr. Fred Hodge

Derrick Scow F. R. Bennett..Capt.Engr. Thomas McLean

Derrick Scow No. 2(No crew)

Derrick Scow No. 3Capt.Engr. Alexander Beron

Derrick Scow McLean No. 4..Capt.Engr. Fred Jondrew

222 **McLouth Steamship Co., The, Marine City, Mich. (Owner and Operator)**
 Pierce McLouth, President, Guy H. Taylor, Port Captain.

Str. John W. CullenCapt. Jas. E. CottrellEngr. Chas. Gaffney

Str. Kalkaska (Appointments not available)
 Str. James H. Prentice (Not in commission)
 Str. Superior (Not in commission)

223 McLouth Steamship Co., Marine City, Mich. (Operator)
 (C. H. Willis) (Owner) Pierce McLouth, Manager, Guy H. Taylor, Port Captain.
 Str. Marysville Capt. Engr.

224 McQueen, J. S., Amherstburg, Ont. (Owner and Operator)
 Tug Falken Capt. J. S. McQueen Engr.
 Sch. Bertie Calkins Capt. Engr.

Donald MacAuloy (See Fleet No. 335)

225 Mackinac Transportation Co., St. Ignace, Mich. (Operator)
 (Mackinac Transportation Co., Detroit, Mich.) (Owner) C. E. Lytle, Manager.
 C. F. Chief Wawatam Capt. J. A. Stufflebeam Engr. J. T. Goulding
 C. F. Sainte Marie Capt. F. G. Ryerse Engr. H. J. Taylor

Madden Coal Corp. (See Fleet No. 226)

226 Madden, George J., 329 Main St., Ogdensburg, N. Y. (Operator)
 (Madden Coal Corp.) (Owner)
 Str. Joseph W. Simpson Capt. Wm. Dessert Engr. Arthur Kinch

227 Mago, B. N., Tonawanda, N. Y. (Operator) (Mago Transit Co.) (Owner)
 Tug B. A. Mago Capt. Engr.
 Deck Scow Mago Transit
 No. I Capt. Engr.
 Deck Scow Mago Transit
 No. II Capt. Engr.

Mahoning Steamship Co. (See Fleet No. 156)

228 Maid of the Mist Steamboat Co., Ltd., Niagara Falls, Ont. (Owner and Operator)
 W. H. Cookman.
 Str. Maid of the Mist
 No. 1 Capt. John Wood Engr. Sylvester McGrath
 Str. Maid of the Mist
 No. 2 Capt. J. J. Quinn Engr. Ed. Ramesbottom

Maisey & Gatfield (See Fleet No. 128)

229 Maley Transportation Line, Sandusky, Ohio (Operator)
 (George W. Maley) (Owner)
 Str. George W. Maley Capt. Engr.
 Str. Ray F. Capt. Engr.
 Str. Reliance Capt. Engr.

230 Manseau Shipyards, Sorel, P. Q., Can. "Les Chantiers Manseau"
 (Owner and Operator)
 Str. Algoma (Not in commission)
 Tug Earl Bess Capt. Alp. Bonin Engr. C. Mondor
 Tug Franklin Capt. Ed. Lamay Engr. J. Paul Hus
 Tug Laurette (Appointments not available)
 Tug Marcia (Appointments not available)
 Tug Robert E. Capt. A. Tremblay Engr. C. Lamirande
 Dredge B. S. L. No. 1 Capt. W. LeBeau Engr. W. LeBeau
 Dredge Bruxelles Capt. Jeffrey Baron Engr. Johnny Dewers

231 Mapes & Ferdon, Ltd., Room 205, 43 St. Sacrament St., Montreal, Que.
(Operator) (Aube Steamship Co., Ltd.) (Owner)

Str. Aube Capt. J. L. Hurley Engr. E. St. German
Str. Sand Merchant Capt. E. Hagen Engr. C. Thompson
Str. Turret Cape Capt. A. Bouvier Engr. A. Lavalle
Str. Turret Court Capt. J. A. Daneau Engr. T. Kennedy

Maplebay Steamship Co., Ltd. (See Fleet No. 397)

232 Marine Iron & Ship Building Co., Duluth, Minn. (Owner and Operator)
John Geistman.

Tug John Abernethy Capt. N. Skafta
Tug Fashion Capt. Wm. McLean Engr. Harry Haines
Tug Marine Capt. Hans C. Hansen
Tug Marjorie Capt. Oscar Abrahamson

233 Marinette Transit Co., 1118 Stanton St., Marinette, Wis. (Owner and Operator)
Thomas E. Finn, Managing Owner.

Str. Sidney O. Neff..... Capt. James Mlnarik Engr. Geo. R. Kyte
Str. Pere Marquette No. 6.... Capt. Gregis Hanson Engr. Fred Zittmer
Bge. Wisconsin (Not operating)

234 Marquette & Bessemer Dock & Navigation Co., Walkerville, Ont.
(Owner and Operator)

C. F. Marquette & Bessemer

No. 2 Capt. T. Heyman Engr. John Abbott

Marquette & Bessemer Dock & Navigation Co. (See Fleet No. 206)

235 Masaba Steamship Co., 811 Sellwood Bldg., Duluth, Minn. (Owner and Operator)

Str. Joe S. Morrow Capt. J. H. Madden Engr. Frank Wetzel

236 Mathews Steamship Co., Ltd., 706 C. P. R. Bldg., Toronto, Ont.
(Owner and Operator)

A. E. Mathews, Port Captain and Managing Owner.

J. G. Fisher, Superintending Engineer.

Str. Arlington Capt. Fred Rock Engr. James Robinson
Str. Bayton Capt. Joe Harden Engr. L. B. Cronk
Str. Berryton Capt. D. A. Kennedy Engr. Sylvester Murray
Str. Birhton Capt. Wm. Fullock Engr. K. B. DeMille
Str. Brookton Capt. Reginald McPherson... Engr. George D. Murphy
Str. Cedarton Capt. Floyd Boulton Engr. Joe Sweeting
Str. Easton Capt. Webb Beatty Engr. F. H. Fawcett
Str. Laketon Capt. N. M. Scott Engr. John F. Myler
Str. Livingston Capt. Andy Livingston Engr. J. H. Duncan
Str. Malton Capt. John A. Smith Engr. Ted Brisbin
Str. Mathewston Capt. John Moles Engr. Douglas McKenzie
Str. Northton Capt. Olaf Gulbronsen Engr. John Gillies
Str. Oakton Capt. Russell Elya Engr. Wilfred Jacks
Str. Riverton Capt. George Bunting Engr. Frank Lancaster
Str. Royalton Capt. W. J. Kirkwood Engr. Donald McConnell
Str. Waterton Capt. Wm. Boulton Engr. Arthur Plante
Str. Wiarton Capt. F. Drever Engr. John Muir
Str. Yorkton Capt. A. McGee Engr. George Jarrell

237 Matson & Grawstrom, Marinette, Wis. (Owner and Operator)

Tug Gwa-Goli Capt. Engr.

238 **Mattison, C. A., Vermilion, Ohio (Operator)**
 (The Kishman Fish Co.) (Owner)
 Tug Edward K. Capt. C. A. Mattison Engr. E. Thompson
 Tug C. A. Mattison Capt. J. P. Nargele Engr. Edward Fitzpatrick
 Tug Rainbow (Not in commission)
 Tug Joseph T. Sloat (Not in commission)

239 **Mellon, Merton H., Bath, Ont. (Owner and Operator)**
 Sch. Maggie L. Capt. George Sudds Engr.

240 **Merchants Lighterage Co., 211 E. North Water St., Chicago, Ill.**
 (Owner and Operator) J. J. Morley, General Manager.
 Lighter Commerce Capt. J. Landon Engr. J. Webb
 Lighter Industry Capt. C. Schoper Engr. J. Hubbard

241 **Michigan Limestone & Chemical Co., Rogers, Mich. (Owner and Operator)**
 Tug Central Capt. Harry Cook Engr. Dan. J. Ryan
 Tug Gifford (Not in commission)
 Tug Frederick T. Kellers..... Capt. Edgar G. Newhouse..... Engr. Frank Weisnewski
 Tug Rogers City Capt. Walter Pepler Engr. Frank Lamp

242 **Michigan State Ferry, Highway Department, Lansing, Mich.**
 (Owner and Operator) A. T. May, Fleet Captain.
 C. F. Mackinaw City Capt. Hillard Bentgen Engr. Ivo Coveyou
 C. F. Sainte Ignace Capt. Barney Sloan Engr. A. C. Watkins

243 **Michigan Transit Corp., N. W. End Municipal Pier, East End Grand Ave.,
 Chicago, Ill. (Owner and Operator)**
 George E. Johnson, General Manager.
 Str. Manitou Capt. W. J. Petroskey Engr. E. J. Weiderholt
 Str. Puritan Capt. J. E. Thorpe Engr. Geo. Simsky

244 **Mid-West Transportation Co., Bay City, Mich (Owner and Operator)**
 Str. Aetna Capt. Winslow U. Randall.... Engr. Thos. Laberdee
 Str. E. M. Bunce Capt. Engr. George Vosburg
 (nee Montfaucon)
 Str. O. J. Lingeman Capt. Fred C. Hector Engr. Andrew Olmstead
 Str. Petcol (Not in commission)

245 **Millard, Capt. C. E., Sarnia, Ont. (Operator)**
 (Langell Transportation Co.) (Owner)
 Str. Simon Langell Capt. J. M. Ferguson Engr. T. Read

246 **Milwaukee Electric Railway & Light Co. (Owner and Operator)**
 Public Service Bldg., Milwaukee, Wis.
 Fred Dornbrook, Chief Engineer of Power Plants.
 Bge. Collier Capt. Henry Ehmke Engr.
 Bge. Emba Capt. Otto Ehmke Engr.

247 **Milwaukee Tug Boat Line, 98 Ferry St., Milwaukee, Wis. (Owner and Operator)**
 Tug W. H. Myer Capt. Henry Etzel Engr. Fred Hasse
 Tug Conrad Starke Capt. Wm. Greenwich Engr. Charles Johnson
 Tug Welcome Capt. Ed. Koster Engr. Robert Wereley

248 **Minister of Marine & Fisheries, Ottawa, Ont. (Owner and Operator)**
 Str. Argenteuil Capt. Thos. W. Weir Engr. Jos. Ranger
 Str. Bellechasse Capt. Philip Gagnon Engr. Jules Lecours
 Str. Bertier Capt. Daniel Beaudet Engr. Leon Salvail
 Str. Concretia Capt. James Martin Engr. Thos. Hazlett
 Str. Detector Capt. Emile Frenette Engr. Adj. Cossette
 Str. Emilia Capt. Donat Lemay Engr. Jos. Peloquin

Str. Grenville Capt. Richard Smith Engr. Chas. Robertson
 Str. Lady Grey Capt. Leon Carriveau Engr. Alx. Laxlamme
 Str. Scout Capt. Murray Barry Engr. George Lessard
 Str. Shamrock Capt. Hector Charbonneau.... Engr. Albert Carpentier
 Str. Murray Stewart Capt. Jos. Ouellette Engr. Stephen Burgess
 Str. Vercheres Capt. Ernest Aussant Engr. Horm Robitaille

249 Minnesota-Atlantic Transit Co., McDougall Terminal, Duluth, Minn. (Operator)

H. T. Hoopes, Port Captain. (Each vessel below owned by a different company)

Str. Ace Capt. J. E. McDonald Engr. D. R. McDonald
 Str. Jack Capt. Gustave Ege Engr. C. M. Ryan
 Str. King Capt. J. O. Heaney Engr. Fred Urban
 Str. Queen Capt. Thos Collins Engr. Warren Cadwell
 Str. Ten Capt. Theo. A. Arntsen Engr. Geo. Campbell

250 Misener, Scott, Manager, 286 North Vidal St., Sarnia, Ont. (Owner and Operator)

Str. Claremont Capt. Scott Misener Engr. John O. McKellar

251 Moffatt, Alfred, Les Escoumains, P. Q., Can. (Operator)

(Laurentide Co., Ltd.) (Owner)

Bge. A. D. (Not in commission)

252 Montreal & Cornwall Navigation Co., Ltd., Pitts St. Wharf, Cornwall, Ont.

(Owner and Operator) Arnold N. Smith, Port Captain.

Str. Britannic Capt. Raoul Lalonde Engr. Noe Chartier

Montreal Forwarding Co., Ltd. (See Fleet No. 320)

253 Montroy & Sons, G. T., Alpena, Mich. (Owner and Operator)

G. T. Montroy, Manager.

Tug J. H. Driscoll Capt. Robert Cooper Engr. B. Persons

254 Morgan Transportation Co., Traverse City, Mich. (Owner and Operator)

Str. Mary Ethel Capt. L. H. Jansen Engr. Marvin Zettel

Morrow Steamship Co. (See Fleet No. 413)

255 Morton Salt Co., 208 West Washington St., Chicago, Ill. (Owner and Operator)

Robert K. Warren, General Superintendent.

Str. Covalt Capt. F. O. Johnson Engr. H. Stokke

256 Moss, E. W., Port Maitland, Ont. (Operator)

(Each vessel listed below owned by a different company)

Tug Caldera Capt. J. P. Siddall Engr. A. Wolfe
 Tug Dorothea D. Capt. Arthur Dougher Engr. Pat. Wilson
 Tug Ellen V. Capt. B. Wilson Engr. J. Mossip
 Tug Glen Erie Capt. Harry Siddall Engr. A. Wilken
 Tug C. C. Lloyd Capt. George Little Engr. R. Shank
 Tug John Logie (Not in commission)
 Tug Maitland Rose Capt. S. McKeown Engr. John McKee
 Tug Oriana Capt. Wm. Thompson Engr. Amos Philips
 Tug Twin Capt. Jas. Hall Engr. Geo. Pope

257 Mullen Coal Co., Amherstburg, Ont. (Owner and Operator)

Str. Alaska Capt. Engr.
 Str. John Mullen Capt. Jos. E. Mahon Engr. Chas. Burns

258 Murphy, A. A., 72 Michigan Ave., Buffalo, N. Y. (Owner and Operator)

Tug D. T. Helm Capt. A. A. Murphy Engr. Wm. Thomson

259 Murphy, James, Ft. William, Ont. (Operator)

(The Western Navigation Co., Ltd.) (Owner)

Str. Anna C. Minch Capt. W. A. Stewart Engr. V. Reive

Nassau Ship & Dredge Co. (See Fleet No. 178)

260 National Sand & Material Co., Welland, Ont. (Owner and Operator)

T. J. Dillon, Manager.

Str. Dick BaxterCapt. H. TuftsEngr. W. Byers
Str. Dick CharlesCapt. T. G. WestonEngr. Donald Paterson
Str. Dick O'ConnorCapt. W. ShieldsEngr. Carl Eckwall
Tug GlideCapt. G. A. Sharen....Engr. Louis Devine
Bge. BadgerCapt. J. CraggEngr. J. Cragg Chatham
Bge. LakegravelCapt. J. McNevinEngr. Jack McNevin
(nee Homer)

National Steamship Co. (See Fleet No. 383)

261 Neff & Co., 68 Wisconsin St., Milwaukee, Wis. (Operator)

(Neff Steamship Co.) (Owner)

Str. Mary K. NeffCapt. John ChamberlinEngr. Archie McNaughty

262 Nessen Transportation Co., 1001 Peoples Gas Bldg., Chicago, Ill. (Operator)

(J. O. Nessen Lumber Co.) (Owner)

Str. ArgoCapt. Gust GundersonEngr.

Str. WotanCapt. Louis HolmesEngr.

263 Newaygo Tug Line, Inc., Wisconsin Rapids, Wis. (Operator)

(Newaygo Tug Line, Inc.) (Port Arthur, Ont.)

Tug ButterfieldCapt. F. A. RyerseEngr. M. W. Gallagher

Tug Erna(Not in operation)

264 New York-Ontario Ferries, Inc., 1529 Marine Trust Bldg., Buffalo, N. Y.

(Owner and Operator) E. W. Neu, Manager.

Str. BedellCapt. James FontaineEngr. Robert Greiner

Str. ChicoraCapt. Bert SennEngr. Charles Beach

Str. JamaicaCapt. Mathew LutzEngr. Wm. Nelson

Str. NewtonCapt. D. JohnEngr. Phil. Stevenson

Str. OrleansCapt. D. WelchEngr. G. Robson

265 New York State Railways, 267 State St., Rochester, N. Y. (Owner and Operator)

C. F. Windsor.....Capt. W. H. Andrews.....Engr. H. H. Ryan

266 Niagara, St. Catharines & Toronto Navigation Co., Ltd. (Operator)

St. Catharines, Ont.

(Canadian Government Railways, "Canadian National Rys.") (Owner)

J. R. Empringham, Superintendent, Park and Marine Service

Str. NorthumberlandCapt. A. Jeffreys.....Engr. A. Mains

267 Niagara, St. Catharines & Toronto Navigation Co., Ltd. (Operator)

St. Catharines, Ont.

(Dalhousie Navigation Co., "Canadian National Rys.") (Owner)

J. R. Empringham, Superintendent, Park and Marine Service

Str. Dalhousie City.....Capt. F. J. Marigold.....Engr. J. H. Brown

268 Nicholson-Erie-Dover Ferry Line, Detroit, Mich. (Owner and Operator)

Str. DoverCapt. F. E. Hamilton.....Engr.

(nee Frank E. Kirby)

Str. ErieCapt. Frank E. Hamilton...Engr. John Hughes

(nee Owana)

269 Nicholson Transit Co., 4683 West Jefferson Ave., Detroit, Mich.

(Owner and Operator)

Bge. Hustler(Appointments not available)

270 **Nicholson-Universal Steamship Co., 4683 W. Jefferson Ave., Detroit, Mich.**
 (Owner and Operator) W. J. Willoughby, Marine Superintendent

Str. City of Bangor.....	Capt.	Engr.
Str. Corolia	Capt. Clyde Tobin.....	Engr. F. M. Rourk
Str. Thomas Davidson.....	Capt. S. Roe.....	Engr. Chas. Elliott
Str. Fellowcraft	Capt. Chas. Hallett.....	Engr. Wm. Warner
Str. Penobscot	Capt. R. M. Leonard.....	Engr. J. Drew
Str. Roumania	(Appointments not available)	
Str. Sonora	Capt. W. J. Mackin	Engr. A. H. Thompson
Str. Sultana	Capt. D. Smith.....	Engr. Chas. Johnson

271 **Nicholson-Universal Steamship Co., 4683 W. Jefferson Ave., Detroit, Mich.**
 (Operator) (Thompson Transit Corp.) (Owner)
 W. J. Willoughby, Marine Superintendent

Str. E. C. Pope.....	Capt. Emery Massman.....	Engr. Chas. Samson
Str. Progress	Capt. Wm. Edgar.....	Engr. Malcom Papworth

North Shore Transit Co. (See Fleet No. 190)

272 **O'Hagan, John J., Tonawanda, N. Y. (Operator)**
 (Bison Steamship Corp.) (Owner)

Str. John Gehm.....	Capt. Wm. Rinn.....	Engr. Bert Rhoads
Str. John J. O'Hagan.....	Capt. Hugh O'Hagan.....	Engr. Thomas Burk

Oakbay Steamship Co., Ltd. (See Fleet No. 398)

273 **Oakes, H. K., Manager, 1959 Union Trust Bldg., Cleveland, Ohio (Operator)**
 (Franklin Steamship Co.) (Owner) Thomas W. Braund, Fleet Engineer

Str. Edward J. Burwind.....	Capt. F. L. Meno.....	Engr. Thomas Griffiths
Str. Emory L. Ford.....	Capt. Edward Fitch.....	Engr. Sigurd Ramberg
Str. Fred G. Hartwell.....	Capt. D. C. Sullivan.....	Engr. Albert H. Amhaus

274 **Oliver, Capt. James, 217 Montreal St., Kingston, Ont. (Owner and Operator)**

Sch. Hattie Hutt.....	Capt. James Oliver.....	Engr.
-----------------------	-------------------------	------------

275 **Ontario Car Ferry Co., Ltd., 226 New Union Station, Toronto, Ont.**
 (Owner and Operator)

C. F. Ontario No. 1.....	Capt. S. H. McCaig.....	Engr. D. L. Smyth
C. F. Ontario No. 2.....	Capt. C. E. Redfearn.....	Engr. J. A. Nicoll

276 **Ontario Construction Co., St. Catharines, Ont. (Owner and Operator)**

Tug Nitchie	Capt. Jas. Mowderley.....
Tug Una	Capt. Thomas

277 **Ontario Gravel Freighting Co., Ltd., 228 Sandwich St., W., Windsor, Ont.**
 (Owner and Operator) Thomas A. Tees, Superintending Engineer

Str. C. W. Cadwell.....	Capt. J. T. Stockwell.....	Engr. Charles Saunders
Str. Sandland	Capt. A. J. Hogue.....	Engr. W. R. Oakes
Tug Thomas A. Tees.....	(Not in commission)	

278 **Ottawa Transportation Co., Ltd., Ottawa, Ont. (Owner and Operator)**

Str. Hall	Capt. J. C. Barclay.....	Engr. J. A. Legault
Str. Denis Murphy.....	Capt. Edouard Francoeur....	Engr. Donat Morinville
Str. Ottawan	Capt. Adolphe Mallette.....	Engr. N. Lavigne
Str. Scotsman	Capt. Wm. Manville.....	Engr. W. Lavigne
Tug Dolphin	Capt. Zeno Levigne.....	Engr. Albert Morinville
Tug Florence	Capt.	Engr.

279 **Owen Sound Transportation Co., Ltd., 1001 Eleventh St., W., Owen Sound, Ont.**
 (Owner and Operator)

Str. John Haggart.....	(Not in commission)	
Str. Manitoulin	Capt. Norman McKay.....	Engr. Wm. Owens

280 Page Equipment & Construction Co., Ltd., The, 3 Rue Des Forges,
Three Rivers, Que. (Owner and Operator)

Tug Jeannette P.....Capt. E. Tellier.....Engr. E. Sauvageau
Tug L. Paul.....Capt. E. Tellier.....Engr. E. Sauvageau

Paisley Steamship Co. (See Fleet No. 69)

Panda Steamship Co. (See Fleet No. 384)

281 Parker, G. W., Lincoln Hotel, Detroit, Mich. (Owner and Operator)

Str. George W. Parker.....Capt. C. W. Warner.....Engr.

282 Paterson, N. M., & Co., Ltd., Fort William, Ont. (Owner and Operator)

Str. BricoldocCapt. C. KirkEngr. Chas Gray
Str. CalgadocCapt. T. Jewett.....Engr. J. H. McMillan
Str. CanadocCapt. J. D. Montgomery....Engr. Louis Butler
Str. CartierdocCapt. B. Angus.....Engr. Ed. Shaw
Str. FortwilldocCapt. A. A. Hudson.....Engr. W. T. Smith
Str. HamildocCapt. N. Miller.....Engr. P. Bonner
Str. KingdocCapt. W. Redfern.....Engr. H. W. Cross
Str. LachinedocCapt. A. Simpell.....Engr. J. Kettles
Str. LavaldocCapt. C. Clark.....Engr. F. H. Gilbert
Str. MantadocCapt. M. Livingstone.....Engr. W. T. Rennie
Str. MondocCapt. C. G. Courtemanch....Engr. O. Burrison
Str. NewbrundocCapt. R. E. Chapman.....Engr. W. Coulson
Str. NovadocCapt. Ken LaRush.....Engr. Percy Pratt
Str. OntadocCapt. H. B. Hunt.....Engr. R. Duguid
Str. PrindocCapt. R. A. Cameron.....Engr. John Barrett
Str. QuedocCapt. Dalton Hudson.....Engr. J. D. Munro

116

Str. SaskadocCapt. R. J. Wilson.....Engr. Frank Collier
Str. SoodocCapt. W. Jewett.....Engr. Ed. Hurl
Str. SoreldocCapt. Roy Simpson.....Engr. John Gilbert
Str. ThordocCapt. E. W. Baker.....Engr. Simon Barr
Str. TroisdocCapt. L. Legendre.....Engr. L. O. Lamoureux
Str. VandocCapt. Jas. N. Foote.....Engr. J. M. Nichol
Str. WellandocCapt. Walt. Nichols.....Engr. C. G. Myatt
Str. WindocCapt. R. D. SimpsonEngr. T. J. Dryburgh
Str. YukondocCapt. Wm. Cunningham.....Engr. W. C. Pickard

283 Payette, John Thomas, Penetanguishene, Ont. (Owner and Operator)
Capt. CoffinStr. VigilantEngr. Murphy

284 Peacock, W. H., Port Hope, Ont., and Arnold D. Way, Port Hope, Ont.
(Owner and Operator)

Sch. Julia B. Merrill.....Capt. W. H. Peacock.....

285 The Pembroke Navigation Co., Pembroke, Ont. (Operator)
(The Pembroke Transportation Co., Ltd.) (Owner)

Str. OiseauCapt. Jos. Tessier.....Engr.

Pembroke Transportation Co., Ltd., The (See Fleet No. 285)

286 Peninsula & Northern Navigation Co., 222 South Water St., Milwaukee, Wis.
(Owner and Operator) J. H. Clark, Managing Director.

Str. ArizonaCapt. J. M. Crawford.....Engr. Lawrence Carpentier
Str. United States.....Capt. H. J. Delatre.....Engr. E. E. Luke

287 Peninsula Tug & Towing Co., Ltd., Warton, Ont. (Owner and Operator)

Str. Edward Buckley.....Capt. D. S. Pruder.....Engr. W. C. Fox
Bge. G. K. Jackson.....Capt. Peter McKinnon.....Engr.

117

288 **Pennsylvania-Ontario Transportation Co. (Owner and Operator)**
 1066 Rockefeller Bldg., Cleveland, Ohio, J. F. Wahl, General Manager.
 Str. Ashtabula Capt. C. F. Meyers..... Engr. S. M. Sylvester

289 **Pere Marquette Line Steamers, Manistee, Mich. (Owner and Operator)**
 Capt. H. L. Sanders, Superintendent.
 Str. Nevada Capt. A. K. Hoxie..... Engr. W. J. Reardon
 Str. Virginia Capt. Walter Dummer..... Engr. M. A. Mathison

290 **Pere Marquette Railway Co., Ford St. Union Depot, Detroit, Mich. (Owner and Operator)** W. L. Bercereau, Superintendent Steamships,
 L. H. Kent, Chief Engineer Steamships.
 C. F. International Capt. J. W. Rigney..... Engr. George Brown
 C. F. Pere Marquette 12... Capt. G. R. McPherson..... Engr. Chas. Henry
 C. F. Pere Marquette 14... Capt. Frank McPherson..... Engr. Wm. Butler
 C. F. Pere Marquette 15... Capt. T. P. McMaster..... Engr. Thos. Loy
 C. F. Pere Marquette 17... Capt. W. H. Van Dyke..... Engr. R. Langrill
 C. F. Pere Marquette 18... Capt. A. Altschwager..... Engr. Fred Snow
 C. F. Pere Marquette 19... Capt. N. MacIsaac Engr. A. W. Ackerman
 C. F. Pere Marquette 20... Capt. Henry Erbe..... Engr. B. E. France
 C. F. Pere Marquette 21... Capt. C. E. Robertson..... Engr. Jos. Koob
 C. F. Pere Marquette 22... Capt. Esten Bahle..... Engr. J. B. Conrad

291 **Peterson, Frank J., Rockefeller Bldg., Cleveland, Ohio (Operator)**
 (Bunce Transit Co.) (Owner)
 Str. John Ericsson..... Capt. Thos. B. Greenway... Engr. George Winter

292 **Peterson, Frank J., Rockefeller Bldg., Cleveland, Ohio (Operator)**
 (Commonwealth Coal Co.) (Owner)
 Bge. Alexander Holley..... Capt. A. C. Thompson..... Engr. W. S. Payne

293 **Peterson, Frank J., Rockefeller Bldg., Cleveland, Ohio (Operator)**
 (Peterson Steamship Co.)
 Str. Frank J. Peterson..... Capt. Charles H. Carstens.. Engr. John L. Scott
Peterson Steamship Co. (See Fleet No. 293)

294 **Petoskey Transportation Co., Petoskey, Mich. (Owner and Operator)**
 Str. J. B. John..... Capt. F. P. Russell..... Engr. Guy Squiers

295 **Pickands, Mather & Co., Union Trust Bldg., Cleveland, Ohio (Operator)**
 (Interlake Steamship Co.) (Owner) W. G. Stewart, Marine Superintendent,
 Charles E. Collins, Fleet Engineer.
 Str. Adriatic Capt. Kenneth McRae..... Engr. Wm. Burnett
 Str. Arcturus Cap. R. J. Recor..... Engr. Leo Arnold
 Str. Calumet Capt. L. W. Norteman..... Engr. Emil Feix
 Str. J. A. Campbell..... Capt. A. R. Beall..... Engr. Elmer Zobel
 Str. Canopus Capt. M. O. Ness..... Engr. E. M. Tims
 Str. Cetus Capt. F. J. Lawrence Engr. J. J. Higgins
 (nee Samuel H. Squire)
 Str. E. A. S. Clarke..... Capt. S. W. Matson..... Engr. Jas. Dungan
 Str. Corvus Capt. Chas. Campbell..... Engr. Chester Bell
 Str. Harry Coulby..... Capt. Wm. A. Reed..... Engr. Jas. Brand
 Str. Crete Capt. N. M. Hetherinton... Engr. E. D. Vollsteadt
 Str. Cygnus Capt. E. O. Noble Engr. Wm. Schunk
 Str. Henry G. Dalton..... Cap. Frank Randall..... Engr. H. H. Kessel
 Str. W. B. Davock..... Capt. W. B. McDonald..... Engr. John Johnson
 Str. Elba Capt. F. R. Goodrow..... Engr. Michael Driscoll
 Str. Hemlock Cap. R. G. Tilley..... Engr. J. E. Vigneron
 Str. Robert Hobson..... Capt. C. C. Stewart..... Engr. W. D. Woods

Str. Harry R. Jones.....	Capt. Ross Campbell.....	Engr. L. M. Richardson
Str. Jupiter	Cap. L. P. Langell.....	Engr. T. W. Johnson
Str. Lagonda	Capt. Guy Smith.....	Engr. Milton Fyre
Str. C. H. McCullough.....	Capt. Nelson Brown.....	Engr. John Carr
Str. Wm. McLauchlan.....	Capt. T. A. McDougall.....	Engr. Wm. Anderson
Str. Samuel Mather.....	Capt. J. S. Neal.....	Engr. F. C. LaLonde
Str. D. O. Mills.....	Capt. W. P. Rouvel.....	Engr. N. Lockhart
Str. Jay C. Morse.....	Capt. Edw. Johnston.....	Engr. J. P. Fetting
Str. Neptune	Capt. C. E. Downs.....	Engr. H. Emersen
Str. Odanah	Capt. R. E. Johnson.....	Engr. Albert Jacobi
Str. Pathfinder	Capt. S. H. Smith.....	Engr. G. A. Brown
Str. Pegasus	Capt. Arnold Evanson.....	Engr. Sam Anderson
Str. Perseus	Capt. Roy Stockdale.....	Engr. Thos. Miller
Str. Colonel James Pick-	Capt. P. M. Cartwright.....	Engr. J. J. Ward
ands		
Str. James H. Reed.....	Capt. W. H. McNeill.....	Engr. R. H. Beauchamp
Str. C. S. Robinson.....	Capt. G. E. Anderson	Engr. A. J. Hoffman
Str. Saturn	Capt. H. C. Inches.....	Engr. Ray Arnold
Str. Charles M. Schwab....	Capt. J. B. Lyons.....	Engr. Hugo Dietlin
Str. Joseph Sellwood.....	Capt. L. J. Lavelly.....	Engr. Chas. Shields
Str. John Sherwin.....	Capt. P. A. Peterson.....	Engr. Otto Elsholz
Str. Amasa Stone.....	Capt. G. A. Macaulay.....	Engr. H. A. Woods
Str. Taurus	Capt. Geo. Cartwright	Engr. John Seymour
Str. Vega	Capt. B. G. Stewart.....	Engr. J. J. Keller
Str. Venus	Capt. L. Haugueland.....	Engr. Lawrence Goulette
Str. Verona	Capt. H. C. Hansen.....	Engr. John Cannon
Str. Victory	Capt. A. C. Drouillard.....	Engr. R. H. Folkert

Str. J. C. Wallace.....	Capt. A. M. Kenkyn.....	Engr. J. L. Martin
Str. Augustus B. Wolvin...	Capt. John Tower.....	Engr. Fred Werner
296 Pickands, Mather & Co., Union Trust Bldg., Cleveland, Ohio (Operator)		
	(Youngstown Steamship Co.) (Owner)	
	W. G. Stewart, Marine Superintendent, Charles E. Collins, Fleet Engineer.	
Str. Youngstown	Capt. J. D. Baird.....	Engr. F. J. Hiller
297 Piepkorn, R. W., Alpena, Mich. (Owner and Operator)		
Tug Falcon	Capt. Kenneth McLean.....	Engr. Fred Lenox Jr.
	Pioneer Steamship Co. (See Fleet No. 176)	
	Pinebay Steamship Co., Ltd. (See Fleet No. 399)	
298 Pine Ridge Coal Co., 716 Union Trust Bldg., Detroit, Mich. (Operator)		
	Fine Ridge Transportation Co.) (Owner)	
	Neal Livingstone, Superintending Engineer.	
Str. C. H. Green.....	Capt. L. W. Lawler.....	Engr. Leon Pollock
	Pine Ridge Transportation Co. (See Fleet No. 298)	
299 Pittsburgh Coal Co. of Ohio, Inc., 1005 Rockefeller Bldg., Cleveland, Ohio		
	(Owner and Operator)	
	W. H. Palmer, Manager, J. P. Doyle, General Superintendent.	
Str. Black Diamond.....	(Not in Commission)	
Str. W. G. Perry.....	Capt. C. E. Barnes.....	Engr. William Schwacofer
Str. Pittsburg	Capt. C. A. Moore.....	Engr. Joseph R. Marshall
300 Pittsburgh Steamship Co., Rockefeller Bldg., Cleveland, Ohio		
	(Owner and Operator)	
	W. P. McElroy, Fleet Captain, Walter J. Harsant, Chief Engineer.	
Str. B. F. Affleck	Capt. G. H. Banker.....	Engr. F. Thurman

Str. George F. Baker.....	Capt. H. J. Clegg.....	Engr. W. A. Lewis
Str. Sir Henry Bessemer....	Capt. A. E. Nunn.....	Engr. Kirby Brake
Str. Clarence A. Black.....	Capt. J. J. McDonald.....	Engr. E. L. Moulton
Str. Eugene J. Buffington..	Capt. John Noble.....	Engr. R. H. Richmond
Str. Robert W. E. Bunsen..	Capt. L. B. Conlin	Engr. W. S. Sills
Str. D. M. Clemson.....	Capt. George Randolph.....	Engr. H. M. Lubahn
Str. Thomas F. Cole.....	Capt. G. M. Ackley.....	Engr. L. Haggan
Str. E. C. Collins.....	Capt. Andrew Grant.....	Engr. F. P. Truelsen
Str. William E. Corey.....	Capt. F. J. Wade.....	Engr. A. C. Lowe
Str. Cornell	Capt. C. J. Kearns.....	Engr. C. E. Timleck
Str. George G. Crawford....	Capt. A. T. Patchett.....	Engr. W. C. McDougall
Str. William B. Dickson....	Capt. F. D. Selee.....	Engr. J. Hasler
Str. Alva C. Dinkey.....	Capt. C. H. Bowen.....	Engr. H. W. Endelman
Str. William Edenborn.....	Capt. John Rourke.....	Engr. W. T. Welsh
Str. Isaac L. Elwood.....	Capt. W. H. Loh.....	Engr. A. Hasler
Str. Sir William Fairbairn..	Capt. R. J. Nims.....	Engr. C. C. Rector
Str. James A. Farrell.....	Capt. F. H. Mallory.....	Engr. C. S. McIntyre
Str. A. H. Ferbert.....	Capt. A. C. Johnson.....	Engr. H. Grotemat
Str. William J. Filbert.....	Capt. G. H. Lane.....	Engr. J. V. Cole
Str. Henry C. Frick.....	Capt. George Bolhouse.....	Engr. J. D. Walker
Str. Frontier	Capt. A. H. Kent.....	Engr. Fred Laphis
Str. Robert Fulton.....	Capt. John Crerar.....	Engr. W. F. Parker
Str. Elbert H. Gary.....	Capt. D. M. LeRoy.....	Engr. Wm. Culp
Str. John W. Gates.....	Capt. Dorin Elliott.....	Engr. W. Churchill
Str. Harvard	Capt. E. F. Bernard.....	Engr. J. B. Kettell
Str. A. F. Harvey.....	Capt. S. C. Allen.....	Engr. G. L. Barnhart
Str. Joshua A. Hatfield.....	Capt. C. M. Conkey.....	Engr. W. P. Diamond

Str. James J. Hill.....	Capt. C. D. Brown.....	Engr. C. D. Reno
Str. Douglas Houghton ...	Capt. G. E. Huckle.....	Engr. W. F. Oehlenschlager
Str. Francis E. House.....	Capt. J. F. Parke.....	Engr. W. A. Marshall
Str. D. G. Kerr.....	Capt. J. T. Gemmell.....	Engr. A. E. Buddemeyer
Str. Richard V. Lindabury..	Capt. H. J. Regan.....	Engr. R. W. Townsend
Str. William R. Linn.....	Capt. C. A. Wallace.....	Engr. P. Christensen
Str. Thomas Lynch.....	Capt. H. D. McLeod.....	Engr. G. D. Johnson
Str. Alexander McDougall..	Capt. Harry Platts.....	Engr. D. Bourlier
Str. William A. McGonagle	Capt. C. J. Grant.....	Engr. H. Edmondson
Str. John H. McLean.....	Capt. F. H. Roach.....	Engr. C. H. Savage
Str. Malietoa	Capt. G. B. McDonald.....	Engr. J. Friesenhan
Str. Maricopa	Capt. C. A. Horton.....	Engr. H. O. Armstrong
Str. Mariposa	Capt. G. T. Comins.....	Engr. H. Lickfeldt
Str. Maritana	Capt. H. C. Beattie.....	Engr. J. R. Jones
Str. Mataafa	Capt. Edward Palm.....	Engr. C. S. McElroy
Str. Maunaloa	Capt. C. S. Christiansen....	Engr. E. H. Oehlenschlager
Str. Pentecost Mitchell.....	Capt. H. R. Johnson.....	Engr. F. J. Manion
Str. J. Pierpont Morgan.....	Capt. H. C. Ashby.....	Engr. H. Gunderson
Str. J. P. Morgan, Jr.....	Capt. A. W. Burrows.....	Engr. B. Henry
Str. Samuel F. B. Morse...	Capt. John McDonald.....	Engr. J. T. Schei
Str. Simon J. Murphy.....	Capt. W. H. McLachlan....	Engr. H. G. Rood
Str. William J. Olcott.....	Capt. Daniel Murphy.....	Engr. W. B. Danforth
Str. William P. Palmer.....	Capt. H. D. Roach.....	Engr. C. A. Suttle
Str. Eugene W. Pargny.....	Capt. W. C. Iler.....	Engr. Wm. Bourlier
Str. George W. Perkins.....	Capt. E. K. Male.....	Engr. F. Limpert
Str. Henry Phipps.....	Capt. P. H. Dunn.....	Engr. E. J. Rae
Str. Gen. Orlando M. Poe..	Capt. H. Finnigan.....	Engr. C. V. Annable

Str. Princeton	Capt. W. J. Millikin.....	Engr. C. Sahlen
Str. Queen City.....	Capt. A. W. Dana.....	Engr. E. R. Rattray
Str. Norman B. Ream.....	Capt. J. A. Smith.....	Engr. W. G. Staley
Str. Rensselaer	Capt. G. G. Burt.....	Engr. T. A. Ives
Str. R. R. Richardson.....	Capt. H. A. Keisk.....	Engr. H. N. Armstrong
Str. Percival Roberts, Jr....	Capt. D. W. McLeod.....	Engr. H. F. Schroeder
Str. Henry H. Rogers.....	Capt. J. C. Murray.....	Engr. G. R. Emrey
Str. William B. Schiller.....	Capt. David Bouille.....	Engr. M. F. Sweeney
Str. Howard L. Shaw.....	Capt. Henry Osier.....	Engr. P. F. McDonnell
Str. McGilvray Shiras.....	Capt. C. E. Peters.....	Engr. W. R. Miller
Str. Sir William Siemens....	Capt. R. M. Crawford	Engr. T. Reinert
Str. George Stenhenson.....	Capt. R. C. Caughell.....	Engr. F. J. Goller
Str. Richard Trimble.....	Capt. J. N. Rolfson.....	Engr. Wm. Dornbrook
Str. James Watt.....	Capt. Frank Davenport.....	Engr. Frank Leng
Str. Peter A. B. Widener....	Capt. H. T. Kelley.....	Engr. J. B. Woods
Str. Homer D. Williams.....	Capt. C. M. Gegenheimer....	Engr. H. E. McIntosh
Str. Zenith City.....	Capt. R. B. Decator.....	Engr. L. E. Darling
Str. August Ziesing.....	Capt. J. W. Burns.....	Engr. F. Schwartz
Bge. Sir Isaac Lothian Bell	Capt. Michael McGory.....	
Bge. Bryn Mawr.....	Capt. D. J. Keefe.....	
Bge. George H. Corliss.....	Capt. Edward Lindberg.....	
Bge. John Fritz.....	Capt. Iver Larsen.....	
Bge. W. Le Baron Jenney..	Capt. J. A. Peterson....	
Bge. Alfred Krupp.....	(Appointments not available)	
Bge. Magna	Capt. John Caroe.....	
Bge. Maia	Capt. Alf Olsen.....	
Bge. Manda	(Appointments not available)	

Bge. Manila	Capt. George Young.....	
Bge. Marsala	Capt. C. M. Christopherson	
Bge. Martha	(Appointments not available)	
Bge. James Nasmyth.....	Capt. W. H. Wright.....	
Bge. John A. Roebling.....	Capt. Donald Graham.....	
Bge. John Smeaton.....	Capt. Robert Thompson.....	
Bge. Sidney G. Thomas.....	Capt. John Brown.....	

301 Playfair, James, Midland, Ont. (Owner and Operator)

Str. James B. Eads.....	Capt. F. Burke.....	Engr. H. Adams
Bge. No. 137.....	Capt. A. Lavigne.....	Engr. G. Bissette
Bge. Glenbogie	Capt. J. Hanley.....	Engr. M. Murphy

302 Point Anne Quarries, Ltd., 304 McKinnon Bldg., Toronto, Ont. (Owner and Operator)

Str. Lake Michigan.....	Capt.	Engr.
Str. John Rolph.....	Capt.	Engr.
Tug Gilbert	Capt.	Engr.
Bge. D. P. Dobbins.....	Capt.	Engr.
Bge. Sophia Minch.....	Capt.	Engr.

Poplarbay Steamship Co. Ltd. (See Fleet No. 400)

303 Port Clinton Lumber & Coal Co., The, Port Clinton, Ohio (Owner and Operator)

Str. D. Dussault.....	Capt. Leroy Silverwood, Jr.	Engr. Bruce Walker
-----------------------	-----------------------------	--------------------

304 Port Colborne & St. Lawrence Navigation Co., Port Colborne, Ont. (Owner and Operator)

Str. Benmaple	Capt. F. R. Johnson.....	Engr. H. W. Fletcher
---------------------	--------------------------	----------------------

305 Porter, J. P., Standifer & Porter Bros., Contractors (Owner and Operator)
New Welland Ship Canal, St. Catharines, Ont.

Tug AliceCapt. J. W. Fardie.....	Engr. W. Chambers
Tug DupreCapt. D. C. Harris.....	Engr. W. Robar
Dredge DelverCapt. N. Hallenbeck.....	Engr. J. Gamble
Dredge FundyCapt. A. Kennedy.....	Engr. F. Bouchard
Dredge ShuniahCapt. A. Leahey.....	Engr. L. Smith E. Eliason
Dredge StewartCapt. G. A. Maker.....	Engr. N. Schabel G. Johnston

306 Port Huron & Sarnia Ferry Co., Port Huron, Mich. (Operator)
(Sarnia Tug & Transit Co.) (Owner)

Fred S. Newton, General Manager, D. Reid, Fleet Engineer.

Str. Hiawatha (Not in commission)

307 Port Huron & Sarnia Ferry Co., Port Huron, Mich. (Owner and Operator)
Fred S. Newton, General Manager, D. Reid, Fleet Engineer.

Str. ArielCapt. E. M. Thomas.....	Engr. J. Meno
Str. City of Port HuronCapt. Guy Geel.....	Engr. F. Cahoon
Str. City of SarniaCapt. Wm. Major.....	Engr. T. Cuttle
Str. LawrenceCapt. James Putnam.....	Engr. Wm. Lenox

308 Port Newark & New England Steamship Co., Newark, N. J. (Operator)
(Raleigh Holding Co.) (Owner)

Str. RaleighCapt.Engr.

309 Post Fish Co., Sandusky, Ohio (Owner and Operator)

Tug Grandon (Appointments not available)

310 Prescott & Ogdensburg Ferry Co., Ltd., Prescott, Ont. (Owner and Operator)
S. J. Delaney, Port Captain W. J. Jento, Superintending Engineer of Fleet

Str. FerdinandCapt. Thomas Boivin.....	Engr. David Richmire
Str. LevisCapt. S. J. Delaney.....	Engr. W. J. Jento
Str. Miss VandenbergCapt. W. Deschene.....	Engr. F. Lavery

Presque Isle Transportation Co. (See Fleet No. 70)

311 Prindiville, John & Sons, 332 South La Salle St., Chicago, Ill. (Operator)
(Frank E. Chamberlin and James W. Prindiville) (Owner)

Str. Parks Foster..... Capt.Engr. Edward Meeh

312 Pringle Barge Line Co., The, 713 Rockefeller Bldg., Cleveland, Ohio
(Owner and Operator) W. R. Pringle, Fleet Captain.

Tug BarkhamsteadCapt. J. B. Pringle.....	Engr. (No appointment)
Tug GuardianCapt. H. C. Buchsieb.....	Engr. P. A. Rivers
B'ge. ConstitutionCapt. Wm. Shafer.....	Engr. Wm. McTaggart
B'ge. Erie	(No appointment)
B'ge. MaidaCapt. Wm. Caulkett.....	
B'ge. SagamoreCapt. Bert Peltier.....	

Producers Steamship Co., The (See Fleet No. 157)

Progress Steamship Co. (See Fleet No. 71)

313 Provincial Paper, Ltd., Port Arthur Division, Port Arthur, Ont.
(Owner and Operator) C. A. Gardner, Supt. Engineer.

Tug Thomas MaitlandCapt. A. Trembley.....	Engr. Bert Debarnardi
Tug Provincial IICapt. Harry Friday.....	Engr. Dave Lanktree

314 Purvis, Capt. John, Gore Bay, Ont. (Owner and Operator)

Tug E. D. M. Purvis.....Capt. John Purvis.....Engr. Wm. Armstrong

315 Pyke Towing & Salvage Co., Kingston, Ont. (Owner and Operator)
Grant Pyke, Manager.

Tug Salvage Price.....Capt. Grant Pyke.....Engr. John Hallen
Bge. Sand Boy.....Capt. Fred Eccles.....
Bge. Stone Boy.....Capt. Phil Ferguson.....
Bge. WarrencoCapt. James Oliver.....
Tug S. A. QueenCapt. Fred Faiter..... Engr. Earney Lambert

316 Quebec & Levis Ferry Co., Ltd., The, St. James St., Quebec, Que.
(Owner and Operator)

Str. John S. Thom.....(Not in operation)

317 Quebec & St. Lawrence Navigation Co., Ltd., 25 Sault au Matelot, Que.
(Owner and Operator) J. L. LaChance, General Manager.

Str. JamaicaCapt. Ernest Vezina..... Engr. Ernest Boivin
Str. Manon Capt. Edouard Cote.....Engr. Thomas Journeault
Str. United Lumberman.....(Appointments not available)
Str. Pelerin(Appointments not available)
Str. Sir Henry.....Capt. Emile Boisvert.....Engr. Agenor Desrochers
Str. Mercier Capt. Emile Plante..... Engr. Auguste Petit

318 Quebec Harbor Commissioners, Quebec, Que. (Owner and Operator)

Tug AvisoCapt. McLean Engr.
Dredge Q. H. C. No. 2.....Capt. J. T. Lambert..... Engr.

319 Rahane Steamship Co., Ltd., 625 Coristine Bldg., Montreal, Que.
(Owner and Operator)

Str. RahaneCapt. William Cornett.....Engr. Jas. R. Groundwater

320 Rahane Steamship Co., Ltd., 625 Coristine Bldg., Montreal, Que. (Operator)
(Montreal Forwarding Co., Ltd.) (Owner)

Str. BrulinCapt. John A. Felker.....Engr. Alexander MacIntosh
Raleigh Holding Co. (See Fleet No. 308)

321 Ramsay Steamship Co., Ltd., 6 Front St., Sault Ste. Marie, Ont.
(Owner and Operator) W. T. Ramsay, Manager.

Str. IndiaCapt. B. Wright.....Engr. W. T. Ramsay

322 Red Star Navigation Co., Toledo, Ohio (Owner and Operator)

Str. GreyhoundCapt. Harry Tyrie..... Engr. C. H. McCarten

323 Reger & Werner Fish Co., Lorain, Ohio (Owner and Operator)

Tug George Edward.....Capt. George Floro.....Engr. John Mahoney
Sc. Str. William F. Pletz..Capt. Louis C. Reger.....Engr. George J. Reger

324 Reid, Capt. J. T., Sarnia, Ont. (Owner and Operator)

Str. Ramona(Not in commission)

325 Reid Towing & Wrecking Co., Port Huron, Mich. (Owner and Operator)
H. B. Reid.

Bge. EleanorCapt. J. T. Reid.....

Lighter Manistique.....Capt. R. H. Knapp..... Engr. Willis Lozon

326 Reid Towing & Wrecking Co., Ltd., Sarnia, Ont. (Owner and Operator)
H. B. Reid.

Tug Constitution Capt. H. B. Reid..... Engr. James Hopwood
Tug Sarnia City.....Capt. J. E. Hayes.....Engr. L. Crawford
Tug Smith Capt. George Hindman.....Engr. J. Rainsbottom
Bge. BrightonCapt. T. M. McCullough.....Engr.

327 Reid Transit Company, Port Huron, Mich. (Owner and Operator)
T. J. Reid, Marine Superintendent.

Str. C. F. Bielman..... (Not in commission)
Str. J. T. Reid Capt. H. Booth..... Engr. D. G. Beauchamp
(nee James B. Neilson)
Str. Spokane Capt. H. Brown..... Engr. F. Kliemann
Str. Westland Capt. G. H. Scott..... Engr. B. J. Beauchamp

328 Reiss, C., Coal Co., The, Sheboygan, Wis. (Owner and Operator)
James Doner, Manager.

Tug Peter Reiss..... Capt. Harry Groh..... Engr. Steve Tessar

329 Reiss Steamship Co., The, Sheboygan, Wis. (Operator)
(The Reiss Steamship Co., Wilmington, Del.) (Owner) James Doner, Manager.

Str. A. M. Byers..... Capt. Wm. Jagenow..... Engr. J. E. McNeill
Str. William K. Field..... Capt. Alex Craigie..... Engr. Alex McLaren
Str. Linford E. Geer..... Capt. Howard N. Leach..... Engr. Frank Duffy
Str. Clemens A. Reiss..... Capt. H. M. Hansen..... Engr. James Nelson
Str. J. L. Reiss..... Capt. R. O. Franforth..... Engr. Charles Van Kuren
Str. John P. Reiss..... Capt. E. J. Lawrence..... Engr. John J. Maloney
Str. Peter Reiss..... Capt. Wm. Landon..... Engr. John A. Richardson
Str. Richard J. Reiss..... Capt. Thomas Moar..... Engr. L. F. Miller
Str. William A. Reiss..... Capt. M. A. Baizaire..... Engr. Henry J. Rake
Str. Alex B. Uhrig..... Capt. John Hoff..... Engr. Martin R. Rake

330 Rinfret, Capt. Joseph, 4345 De Lorimer St., Montreal, Que.
(Owner and Operator)

Str. Garden City..... Capt. Jos. Rinfret..... Engr. Adelard Gendron

Rutland-Lake Michigan Transit Co. (See Fleet No. 369)

331 Rockport Steamship Co., Sheboygan, Wis. (Operator)
(Rockport Steamship Co., Wilmington, Del.) (Owner) James Doner, Manager.

Str. John A. Kling..... Capt. James Rathburn..... Engr. Ernest Pickering
Str. Charles C. West..... Capt. Ed. H. Doner..... Engr. M. G. Cook

332 Roe Brothers, Harbor Springs, Mich. (Owner and Operator)

Str. America Capt. Chas. Roe..... Engr. Henry J. Roe

333 Roen Steamboat Service, Charlevoix, Mich. (Owner and Operator)

Str. Fred W. Green..... Capt. John Roen..... Engr. George La Blance
(nee Craycroft)

Str. Marquis Roen..... Capt. Albert La Blance..... Engr. Henry Isaksen

Bge. Interlaken Capt. Mat Overvog..... Engr.

Bge. Frank D. Philips..... Capt. Snut Svendsohl..... Engr.

334 Rolson, James, 1416 North Kedzie Ave., Chicago, Ill. (Owner and Operator)

Tug Carter H. Harrison..... Capt. James Rolson..... Engr. Albert Anderson

335 Rondeau Tug Co., Blenheim, Ont. (Operator) (Donald MacAuloy) (Owner)

Tug Thistle Capt. Norman MacAuloy..... Engr. Wm. Fowlis

336 Ruelle's Tug Line, 2024 Atwater St., Detroit, Mich. (Operator)

(Sayen & Candler Co.) (Owner) Alex Ruelle, Supt. Engineer.

Tug Samuel J. Dark..... Capt. Gilbert Townsend..... Engr. John Sayen

337 Russell, John E., Towing & Salvage (Owner and Operator)

Reford Bldg., 217 Bay St., Toronto, Ont.

Tug Joseph L. Russell..... Capt. Robt. Graham..... Engr. Wm. Wright

Bge. James F. Cahill..... Capt.

Bge. Colpet Capt. James Quinn.....

351 Service Gravel Co., of Marysville, Mich. (Operator) (Chas. F. Mann) (Owner)

Str. Henry Houghton (Not in commission)
 Str. India Capt. R. B. Young Engr. Stanley Burns
 Str. Marysville Capt. C. Warner Engr. Wm. Enright

352 Sharp, William H., Bay City, Mich. (Owner and Operator)

Tug Witch Capt. John Dawson Engr. Bert Hughes

353 Shenango Furnace Co., 1961 Union Trust Bldg., Cleveland, Ohio (Operator)

(Shenango Furnace Co., Pittsburgh, Pa.) (Owner)
 C. J. Peck, Manager, W. F. Riley, Superintendent.

Str. Col. James M. Schoon-Capt. Frank H. Ott Engr. Albert Fritz
 maker

Str. Shenango Capt. Benson Fox Engr. D. J. Milloy
 Str. William P. Snyder, Jr... Capt. J. F. Jones Engr. Wm. Stroble

354 Shields & Weston, Sault Ste. Marie, Mich. (Owner and Operator)
 Samuel Shields.

Tug Aloha Capt. Earl Weston Engr.
 Tug O. E. Parks Capt. William Haynes Engr.
 Tug Frank Weston Capt. Samuel Shields Engr.

355 Sincennes-McNaughton Line, Ltd., 73 Common St., Montreal, Que.
 (Owner and Operator)

Tug Alaska Capt. Jos. Bibeau Engr. D. Lavallee
 Tug Conqueror Capt. Z. Cadieux Engr. E. Saivageau
 Tug Andree Dupre Capt. H. Filteau Engr. E. Hamelin
 Tug Yvon Dupre, Jr. Capt. Jos. Mongeau Engr. O. Beaucage
 Tug Eureka Capt. L. Lenay Engr. E. Lavalee

Tug Felicia Capt. F. Houde Engr. J. Cournoyer
 Tug Fredmac Capt. E. Blais Engr. T. Sheridan
 Tug Hudson Capt. J. Laforest Engr. P. Cournoyer
 Tug Jeannette R. (Not in commission)
 Tug Macsin Capt. J. Millette Engr. J. Laforest
 Tug Mathilda Capt. U. Latraverse Engr. J. Bernard
 Tug Gerald Morgan (Not in commission)
 Tug Muscallonge Capt. Z. Legault Engr. P. Moreau
 Tug Myra Capt. Ph. Bibeau Engr. J. Beaucage
 Tug John Pratt Capt. Jos. Corunoyer Engr. Ed. Mongeon
 Tug Pierre Racine Capt. N. Mongeau Engr. Jos. Laviolette
 Tug Rival Capt. D. Mongeau Engr. J. Lavellee
 Tug Rosalie L. Capt. P. Lavellee Engr. A. Lesperance
 Tug Sinmac Capt. Ph. Picard Engr. A. Baribeau
 Tug Virginia Capt. E. Houde Engr. A. Lemay
 Bge. Arthur (Not in commission)
 Bge. Ashland Capt. A. Monette
 Bge. Augustus Capt. A. DeRepentigny
 Bge. Burma Capt. J. Monette
 Bge. J. I. Case (Not in commission)
 Bge. Compton Capt. Jos. Lebeuf
 Bge. Dunmore Capt. S. Bibeau
 Bge. Hector Capt.
 Bge. Kildonan Capt.
 Bge. Kingston Capt.
 Bge. Lapwing Capt.
 Bge. Melrose Capt. Jos. Leduc

Bge. Menominee Capt.

Bge. Arthur Morgan Capt.

Bge. Nellie Reddington Capt. A. Boucher

Bge. Isaac Stephenson Capt.

Bge. Henry Witbeck Capt.

Bge. Woodlands (Not in commission)

356 Smeed Box Co., 1878 Scranton Rd., Cleveland, Ohio (Owner and Operator)
Wm. J. Ellenberger.

Bge. Halsted Capt. Engr.

Leathem Smith-Cliffs Co. (See Fleet No. 81)

357 Smith, Leathem D., Dock Co., Sturgeon Bay, Wis. (Owner and Operator)
Tug Leathem D. Smith Capt. Wm. Boyd Engr. Edward Weber

358 Smith, Leathem D., Stone Co., Sturgeon Bay, Wis. (Operator)
(Leathem D. Smith) (Owner) Ed. Weber, Engineer of Fleet.

Bge. Adriatic (Not in commission)

Smith-Truby Sand Co. (See Fleet No. 82)

359 Solman, Lawrence, 146 John St., Toronto, Ont. (Owner and Operator)
Str. Clark Brothers Capt. Engr.

Str. John Hanlan Capt. Engr.

Str. Mazeppa Capt. Engr.

360 Solman, Lawrence, 146 John St., Toronto, Ont. (Operator)
(Toronto Ferry Co., Ltd.) Capt. C. Wakeley, Superintending Engineer.

Str. Bluebell Capt. Engr.

Str. Island Queen Capt. Engr.

Str. Jasmine Capt. Engr.

136

Str. Luella Capt. Engr.

Str. Mayflower Capt. Engr.

Str. Primrose Capt. Engr.

Str. Trillium Capt. Engr.

361 Sowards, Capt. J. F., Kingston, Ont. (Owner and Operator) W. J. Driver.
Str. Patdoris Capt. J. Doyle Engr. Jos. Lamoreaux

Bge. George T. Davie Capt. P. Leager Engr.

Ltr. Bge. White Star Capt. A. Oliver Engr.

Sprucebay Steamship Co., Ltd. (See Fleet No. 401)

362 Stalker, Hugh, Collingwood, Ont. (Owner and Operator)
Tug Hugh Stalker Capt. C. Wright Engr. H. Morris

363 Standard Oil Co. of Indiana, Whiting, Ind. (Owner and Operator)
James E. Evans, Manager Marine Department.

Str. W. P. Cowan Capt. Leonard Johnsen Engr. David Wellman

Str. Renown Capt. H. A. Hansen Engr. W. G. Thorn

Tug Outgamie Capt. Andrew Jensen Engr. Arthur L. Lippie

Bge. C Capt. Cm. R. Leith Engr.

Str. Robert W. Stewart Capt. Julius Lang Engr. T. W. Laing

364 State of Ohio, Put-in-Bay, Ohio (Operator)
(Ohio Fish & Game Division) (Owner)

Tug Oliver H. Perry Capt. Otto Biemiller Engr. Wm. Kumm

365 Steinbrenner, Henry, Manager, 1001 Rockefeller Bldg., Cleveland, Ohio
(Operator) (Kinsman Transit Co.) (Owner)

Str. Matthew Andrews Capt. H. W. Stewart Engr. John G. Beyer

Str. Worrell Clarkson Capt. J. W. Kelley Engr. Jas. Berquist

137

Str. George M. Humphrey Capt. A. E. Rankin Engr. W. H. Miller
 Str. Philip Minch Capt. J. C. McLean Engr. W. S. Fandrei
 Str. Henry Steinbrenner Capt. W. F. Haydet Engr. W. S. Tweedale

Stewart Furnace Co. (See Fleet No. 32)

366 Sturgeon Bay Stone Co., Sawyer, Wis. (Owner and Operator)

Bge. Ida Corning (Not in commission)
 Bge. Oak Leaf (Not in commission)

367 Sullivan, D., & Co., Mgrs., 208 South La Salle St., Chicago, Ill. (Operator)
 (Chicago Navigation Co.) (Owner)

Str. Otto M. Reiss Capt. Elmer Weborg Engr. John Thomas
 Str. William E. Fitzgerald.... Capt. W. S. Macqueen Engr. James Linton

368 Sullivan, D., & Co., Mgrs., 208 South La Salle St., Chicago, Ill. (Operator)
 (Gartland Steamship Co.) (Owner) E. F. Harmon.

Str. William H. Wolf Capt. A. E. Callam Engr. R. Elhamer

369 Sullivan, D., & Co., Mgrs., 208 South La Salle St., Chicago, Ill. (Operator)
 (Rutland-Lake Michigan Transit Co.) (Owner) E. F. Harmon.

Str. Back Bay Capt. W. C. Ruddle Engr. Geo. McCullough
 Str. Bennington Capt. E. A. DuBrule Engr. Sylvester Stoeber
 Str. Brandon Capt. Wm. Russell Engr. Wm. Walder
 Str. Brockton Capt. Wm. Flanders Engr. Fred Harmon
 Str. Burlington Capt. Engr. F. B. Weisiger

370 Sullivan, M., Dredging Co., Detroit, Mich. (Owner and Operator)

Tug Columbia Capt. J. Picard Engr. Wm. Adams
 Tug Edwin Denby Capt. Henry Cook Engr.
 Dredge Gladiator Capt. J. Stapleton Engr.

138

Dredge Hercules Capt. H. Stapleton Engr. Daniel Sheehan
 Drill Boat Destroyer (Appointments not available)
 Drill Boat T. N. T. (Appointments not available)
 Bge. Derrick Jupiter Capt. Wm. McCoy Engr. John Ojibway

371 Superior Sand & Gravel Co., 1101 Dime Saving Bank Bldg., Detroit, Mich.
 (Owner and Operator)

Str. Frank C. Osborn Capt. Engr.

Superior Steamship Co. (See Fleet No. 385)

372 Superior Transit Co., 917 Dime Saving Bank Bldg., Detroit, Mich.
 (Owner and Operator)

Str. N. J. Nessen Capt. Jos. Allor Engr. B. J. Beauchamp

373 Terminal Transit & Towing Co., Fort William, Ont. (Owner and Operator)
 A. E. Fader, Manager.

Str. Islet Prince Capt. M. L. Carney Engr. Malcom Currie
 Lighter Nipigon

Tug W. J. Emerson Capt. R. McMinnimee Engr. David Weir

374 Texas Co., The, Lockport, Ill. (Operator)

The Texas Co., 17 Battery Pl., New York (Owner)

Tug Harvey Capt. H. S. Miller Engr. Paul Smith
 Bge. Texaco Capt. J. B. Moore Engr.

375 Thompson, R. P., Port Huron, Mich. (Operator) (Thompson Tug Co.) (Owner)
 Tug Lotus Capt. A. T. Thompson Engr. L. H. Carpenter
 (nee Strohn)

Tug Victory Capt. W. P. Thompson Engr. A. Chiuski
 Bge. Isabella Sands Capt. John Simpson Engr. S. Ferguson

139

Thompson Transit Corp. (See Fleet No. 271)

Thompson Tug Co. (See Fleet No. 375)

376 Thousand Island Navigation Co., Ltd., Foot of Brock St., Kingston, Ont.
(Owner and Operator)

Str. Champion Capt. Wm. LaSha Engr. Mathew Dorey
Str. Frontenac Capt. Jno. A. Carnegie

377 Toledo Builders Supply Co., 432 Spitzer Bldg., Toledo, Ohio
(Owner and Operator) James P. Degnan.

Str. T. B. S. Capt. Jas. Slavin Engr. Clark Gould
Str. Walter D. Capt. R. L. Pocott Engr. Elvery Bunker

378 Tomlinson, G. A., Manager, Duluth, Minn. (Owner and Operator)

Warren C. Jones, Fleet Captain, Edward C. Davidson, Superintending Engineer.
Str. Coulee Capt. Engr.

379 Tomlinson, G. A., Manager, Duluth, Minn. (Operator)
(Continental Steamship Co.) (Owner)

Warren C. Jones, Fleet Captain, Edward C. Davidson, Superintending Engineer.
Str. L. M. Bowers Capt. Engr.

380 Tomlinson, G. A., Manager, Duluth, Minn. (Operator)
(Duluth Steamship Co.) (Owner)

Warren C. Jones, Fleet Captain, Edward C. Davidson, Superintending Engineer.
Str. D. M. Philbin Capt. Engr.

381 Tomlinson, G. A., Manager, Duluth, Minn. (Operator)
(Globe Steamship Co.) (Owner)

Warren C. Jones, Fleet Captain, Edward C. Davidson, Superintending Engineer.
Str. Cuyler Adams Capt. Engr.

Str. Ball Brothers Capt. Engr.
Str. Frank C. Ball Capt. Engr.
Str. James Davidson Capt. Engr.

382 Tomlinson, G. A., Manager, Duluth, Minn. (Operator)
(Inter Ocean Steamship Co.) (Owner)

Warren C. Jones, Fleet Captain, Edward C. Davidson, Superintending Engineer.
Str. James E. Davidson Capt. Engr.
Str. Sierra Capt. Engr.

383 Tomlinson, G. A., Manager, Duluth, Minn. (Operator)
(National Steamship Co.) (Owner)

Warren C. Jones, Fleet Captain, Edward C. Davidson, Superintending Engineer.
Str. Frank W. Hart Capt. Engr.
Str. C. W. Watson Capt. Engr.

384 Tomlinson, G. A., Manager, Duluth, Minn. (Operator)
(Panda Steamship Co.) (Owner)

Warren C. Jones, Fleet Captain, Edward C. Davidson, Superintending Engineer.
Str. William H. Warner Capt. Engr.

385 Tomlinson, G. A., Manager, Duluth, Minn. (Operator)
(Superior Steamship Co.) (Owner)

Warren C. Jones, Fleet Captain, Edward C. Davidson, Superintending Engineer.
Str. George G. Barnum Capt. Engr.

386 Tomlinson, G. A., Manager, Duluth, Minn. (Operator)
(Triton Steamship Co.) (Owner)

Warren C. Jones, Fleet Captain, Edward C. Davidson, Superintending Engineer.
Str. Rufus P. Ranney Capt. Engr.

387 Tomlinson, G. A., Manager, Duluth, Minn. (Operator)
 (Zenith Steamship Co.) (Owner)
 Warren C. Jones, Fleet Captain, Edward C. Davidson, Superintending Engineer.
 Str. M. E. FarrCapt.Engr.
 Str. Hoover & MasonCapt.Engr.

388 Toronto City Council, Toronto, Ont. (Owner and Operator)
 R. C. Harris, Commissioner of Works.
 C. Margerison, Superintendent Marine Section.

Tug G. R. GearyCapt. F. A. CookEngr. J. Taylor
 Tug NationalCapt. O. JohnsonEngr. H. Baillie

Toronto Ferry Co., Ltd. (See Fleet No. 360)

389 Toronto, Hamilton & Buffalo Navigation Co., Hamilton, Ont.
 (Owner and Operator)

Str. Maitland No. 1.....Capt. J. W. Keeley.....Engr. Ernest Baker

390 Toronto Harbor Commission, Toronto, Ont. (Owner and Operator)
 J. G. Langton, General Manager F. A. Burgar, Construction Engineer

Tug No. 1 Emily Stewart..Capt. W. J. Stitt.....Engr. H. Shaughnessy
 Tug No. 2 Mary Stewart...Capt. P. J. Shaw.....Engr. J. Harrold
 Tug No. 3 Viper.....Capt. Robt. Dowd.....Engr. John Cameron
 Dredge Cyclone.....Capt. Geo. Rose.....Engr. Alex Chambers

391 Toronto Insurance & Vessel Agency, Ltd., 64 King St., East Toronto, Ont.
 (Owner and Operator) J. B. Foote

Str. Geo. R. Donovan.....Capt. J. E. Mann.....Engr. R. H. Plunket
 Str. James B. Foote.....Capt. W. J. Brown.....Engr. W. Wells
 Str. D. B. Hanna.....Capt. H. S. Belling.....Engr. H. MacDonald

392 Traverse City Transportation Co., Traverse City, Mich. (Owner and Operator)
 Str. M. H. Stuart.....Capt. Chas. Anderson.....Engr. Christan Christanson

393 Tree Line Navigation Co., Ltd., Montreal, Que. (Operator)
 (Ashbay Steamship Co., Ltd.) (Owner) J. B. Lappen, Superintendent Engineer

Str. AshbayCapt. H. H. Thorn.....Engr. Wm. Byers

394 Tree Line Navigation Co., Ltd., Montreal, Que. (Operator)
 (Beechbay Steamship Co., Ltd.) (Owner) J. B. Lappen, Superintendent Engineer

Str. BeechbayCapt. M. A. Hornsby.....Engr. D. S. Crawford

395 Tree Line Navigation Co., Ltd., Montreal, Que. (Operator)
 (Cedarbay Steamship Co., Ltd.) (Owner)

Str. CedarbayCapt. Paul Morinville.....Engr. D. Vezina

396 Tree Line Navigation Co., Ltd., Montreal, Que. (Operator)
 (Elmbay Steamship Co., Ltd.) (Owner) J. B. Lappen, Superintendent Engineer

Str. ElmbayCapt. Nap. Tremblay.....Engr. D. Brunelle

397 Tree Line Navigation Co., Ltd., Montreal, Que. (Operator)
 (Maplebay Steamship Co., Ltd.) (Owner) J. B. Lappen, Superintendent Engineer

Str. MaplebayCapt. E. A. Booth.....Engr. J. Lentz

398 Tree Line Navigation Co., Ltd., Montreal, Que. (Operator)
 (Oakbay Steamship Co., Ltd.) (Owner) J. B. Lappen, Superintendent Engineer

Str. OakbayCapt. C. E. Kennedy.....Engr. R. Gibson

399 Tree Line Navigation Co., Ltd., Montreal, Que. (Operator)
 (Pinebay Steamship Co., Ltd.) (Owner) J. B. Lappen, Superintendent Engineer

Str. PinebayCapt. J. Daignault.....Engr. Geo. Verrier

400 **Tree Line Navigation Co., Ltd., Montreal, Que. (Operator)**
 (Poplarbay Steamship Co., Ltd.) (Owner) J. B. Lappen, Superintendent Engineer
 Str. Poplarbay Capt. Theo. Marchand..... Engr. J. B. Marchand

401 **Tree Line Navigation Co., Ltd., Montreal, Que. (Operator)**
 (Sprucebay Steamship Co., Ltd.) (Owner) J. B. Lappen, Superintendent Engineer
 Str. Sprucebay Capt. J. R. Montgomery..... Engr. T. S. Wilson

402 **Tree Line Navigation Co., Ltd., Montreal, Que. (Operator)**
 (Willowbay Steamship Co., Ltd.) (Owner) J. B. Lappen, Superintendent Engineer
 Str. Willowbay Capt. Jos. Duguay..... Engr. A. Gagne

403 **Trevisa Steamship Co., Ltd., P. O. Box 656, Montreal, Que. (Owner and Operator)**
 John Waller, Superintending Engineer
 Str. Trevisa Capt. P. V. Mahoney..... Engr. Owen Williams

Triton Steamship Co. (See Fleet No. 386)

404 **United States & Dominion Transportation Co. (Owner and Operator)**
 205 North Michigan Ave., Chicago, Ill.
 Str. America Capt. Edward C. Smith..... Engr. Frank McMillan

405 **U. S. Engineer Department, 406 Federal Bldg., Milwaukee, Wis.**
(Owner and Operator)
 John J. Kingman, District Engineer E. M. Nisen, Civil Engineer

Tug Cumberland Capt. Algie Alexander..... Engr. John P. Riley
 Tug Manitowoc Capt. C. C. Fowler..... Engr. Charles Wondrasek
 Tug Marinette Capt. Palmer E. LaPlante.. Engr. Andrew Tollefson
 Str. Drg. Meade..... Capt. William Rosie..... Engr. Jess G. Lanridge
 Bge. Milwaukee Capt. Henry Devine..... Engr.
 Bge. Riprap Capt. Forest Olson..... Engr.

144

406 **United Fuel & Supply Co., 200 Transportation Bldg., Detroit, Mich.**
(Owner and Operator) Homer W. Smith, Marine Manager

Str. H. Dahlke..... Capt. M. A. Larrabee..... Engr. T. F. Merriman
 Str. F. E. Harvey..... Capt. G. H. Ferguson..... Engr. J. A. Leslie
 Str. Charles Heiden..... Capt. Wm. Ames..... Engr. Prosper Tennant
 Str. F. C. Osborn..... Capt. R. Donaldson..... Engr. Raymond Balfour
 Str. Pearson Capt. J. Allan..... Engr. William Bonnah
 Tug Ufasco Capt. H. W. Smith..... Engr.
 Dredge Huron..... Capt. Engr. A. L. Hatch

407 **United States Lighthouse Service, Tenth District, Buffalo, N. Y.**
(Owner and Operator) Roscoe House, Superintendent of Lighthouses

L. H. Tender Str. Crocus.... Capt. John P. Bourke..... Engr. H. K. Loveless
 Tug Birch Capt. F. P. Barker..... Engr. F. H. Jaeger

408 **United States Lighthouse Service, Eleventh Lighthouse District, Detroit, Mich.**
(Owner and Operator)
 Charles A. Park, Superintendent of Lighthouses
 Irving L. Gill, First Assistant Superintendent

L. H. Tender
 Str. Amaranth Capt. G. Gundersen..... Engr. Frank J. Pospeshil
 L. H. Tender Str. Aspen..... Capt. Wm. G. Taylor..... Engr. Oscar B. Anderson
 L. H. Tender Str. Clover... Capt. Nils L. Larson..... Engr. Richard Burdeno
 L. H. Tender Str. Marigold Capt. A. Gustafson..... Engr. George Galbraith
 Str. Lightship No. 96..... Capt. Frank Leimbach..... Engr. Wm. B. Cushman
 Str. Lightship No. 99..... Capt. John S. Martino..... Engr. Simon P. Lowery
 Bge. Lightship No. 75..... (nonattended)

145

**409 United States Lighthouse Service, Twelfth Lighthouse District, Milwaukee, Wis.
(Owner and Operator)**

L. H. Tender	Str. Hyacinth	Capt. H. W. Maynard.....	Engr. J. R. McCauley
L. H. Tender	Str. Sumac....	Capt. J. K. Olsen.....	Engr. G. W. Crawford
Str. Lightship	No. 56.....	Capt. W. J. Stewart.....	Engr. J. Peters
Str. Lightship	No. 82.....	Capt. C. Christiansen.....	Engr. W. Hanson
Str. Lightship	No. 95.....	Capt. C. Carlson.....	Engr. H. S. Robertson
Str. Lightship	No. 98.....	Capt. E. Garrett.....	Engr. P. Sharkey
Str. Lightship	No. 103.....	Capt. H. S. Hill.....	Engr. J. C. McDonald
Bge. Lightship	No. 77.....	Capt. A. Hanson.....	Engr.
Bge. Lightship	No. 89.....	Capt. G. J. Navarre.....	Engr. P. Eustice

**410 United States Steel Products Co., Rockefeller Bldg., Cleveland, Ohio
(Operator) (United States Steel Products Co., New York City) (Owner)
P. F. Donnelly, Port Captain B. E. Meurk, Superintending Engineer**

M. S. Steel	Chemist.....	Capt. A. F. Woods.....	Engr. W. S. Connauton
M. S. Steel	Electrician.....	Capt. J. N. Brown.....	Engr. W. R. Wright
M. S. Steelmotor	Capt. H. P. Irvine.....	Engr. H. T. Petersen
M. S. Steelvender	Capt. J. G. Woerpel.....	Engr. W. C. Van Rooy

**411 Valley Camp Steamship Co., B. of R. T. Bldg., Cleveland, Ohio
(Owner and Operator)**

R. J. Paisley, Manager W. B. Pilkey, Marine Superintendent

Str. Harry T. Ewig....	Capt. Howard Millington....	Engr. H. B. Muhltner
Str. John McCartney Kennedy	Capt. C. H. Mohr.....	Engr. Robert Holt
Str. E. G. Mathiott.....	Capt. Jos. A. Thodey.....	Engr. F. W. Hunt
Str. S. B. Way	Capt. Ralph E. Jones.....	Engr. W. J. Radke

**412 Valley Camp Steamship Co., B. of R. T. Bldg., Cleveland, Ohio (Operator)
(Lakewood Steamship Co.) (Owner)**

R. J. Paisley, Manager W. B. Pilkey, Marine Superintendent

Str. Britt	Capt. G. A. Montgomery....	Engr. Chas. Wolvin
(nee G. N. Wilson)		
Str. McFarland	Capt. G. R. Doner.....	Engr. Jos. Garant
(nee Reeb)		

**413 Valley Camp Steamship Co., B. of R. T. Bldg., Cleveland, Ohio (Operator)
(Morrow Steamship Co.) (Owner)**

R. J. Paisley, Manager W. B. Pilkey, Marine Superintendent

Str. John Anderson.....	Capt. F. A. Brune.....	Engr. A. W. Muhltner
Str. Thomas Britt.....	Capt. C. W. Fox.....	Engr. E. D. Jacques
Str. D. E. Callender.....	Capt. H. S. Perkins.....	Engr. H. Frits
Str. A. E. R. Schneider.....	Capt. Jas. Cannally.....	Engr. A. A. Smedley

414 VerDuin, William, Grand Haven, Mich. (Owner and Operator)

Tug C. J. Bos.....	Capt. Wm. Ver Duin.....	Engr. John Ver Hocks
--------------------	-------------------------	----------------------

Virginia Steamship Co., The (See Fleet No. 158)

415 Wabash Railway Co., Detroit, Mich. (Operator)

(Wabash Railway Co., St. Louis, Mo.) (Owner)

R. Aiken, Superintendent of Ferries

C. F. Detroit	Capt. G. W. Honner.....	Engr. H. Lowry
C. F. Manitowoc	Capt. Russell Aikin.....	Engr. W. F. Taylor
C. F. Transfer	Capt. W. Norvell.....	Engr. E. J. Fitzgerald
C. F. Transport	Capt. Enoch Cram.....	Engr. D. A. Patterson

416 Walkerville & Detroit Ferry Co., Foot Joseph Campau Ave., Detroit, Mich.
(Owner and Operator)

Joseph Fitzsimmons, Superintending Engineer

Str. Essex Capt. A. Bailey Engr. William Schomaker
 Str. Halcyon Capt. John J. McCarthy..... Engr. Charles Lowrey
 Str. Wayne Capt. John Rathburn..... Engr. P. McLaren

Wallaceburg Sand & Gravel Co., Ltd. (See Fleet No. 124)

Way, Arnold D. (See Fleet No. 284)

417 Weaver, F. P., Coal Co., Ltd., 146 Notre Dame St., W., Montreal, Que.
(Operator)

(St. Lawrence Coal Co., Ltd.) (Owner)

Str. Weavercoal Capt. A. Goulet..... Engr. Patrick Audette

418 Weddell, Rob G., Trenton, Ont. (Owner and Operator)

Str. Daisy (Appointments not available)
 Str. M. Sicken..... Capt. B. Bowen..... Engr. W. B. Clark
 Tug Aurelia Capt. Nap Miron..... Engr. Fred Rupert
 Tug Minitaga (Appointments not available)
 Tug Rob G. Weddell..... Capt. M. Palmeteer..... Engr. A. Douch
 Bge. Katie Brainard..... (Appointments not available)
 Bge. Hilda Capt. Sam LeBoeuf..... Engr.
 Bge. Montreal Capt. C. Brunet..... Engr.
 Bge. Nadine Capt. Armand Lalonde.....
 Bge. White & Friar..... Capt. Max Gamelin.....

419 Wells, L. A., Construction Co., 30 Euclid Arcade, Cleveland, Ohio
(Owner and Operator)

Tug J. R. Sprankle..... Capt. Samuel Moore..... Engr. Leonard Upper
 Derrick Scow Interstate..... Capt. Joseph Bocock Engr. Frank Moorman
 Derrick Scow Wawasee..... Capt. Hans Seblon..... Engr. J. A. Day

Western Navigation Co., Ltd., The (See Fleet No. 259)

420 Western Transportation Co., 159 North State St., Chicago, Ill.
(Owner and Operator)

W. H. Cochranee.

Str. Columbia Capt. Engr.
 Str. Florida Capt. Engr.
 Str. Anna C. Wilson..... Capt. Engr.

Weston & Shields (See Fleet No. 354)

421 West Ports Steamship Line, Milwaukee, Wis. (Owner and Operator)
 Louis N. Biron, General Manager, F. A. Dority, Superintendent.

Str. Kenosha Capt. A. M. Noble..... Engr. P. Herjuan
 Str. Sheboygan Capt. S. F. Madden..... Engr. Wm. Toslund
 Str. Waukegan (Appointments not available)

422 White Star Tug Line, Foot of Genesee St., Buffalo, N. Y.
(Owner and Operator)

Tug M. D. Carrington..... Capt. J. W. Baker..... Engr. Charles Dovey
 Tug John Perew..... Capt. Geo. Lord..... Engr. Charles Brigham

423 White Star Navigation Co., Foot Griswold St., Detroit, Mich.
(Owner and Operator)

C. F. Bielmann, Jr., General Manager.

Sr. Tashmoo Capt. Chas. G. Merckel..... Engr. John McCarten

424 Whitney Brothers Co., 909 Alworth Bldg., Duluth, Minn. (Owner and Operator)

Tug Major Dana..... (Appointments not available)
Tug E. G. Maxwell..... Capt. W. T. Jones..... Engr. Chas. Morrison
Tug William A. Whitney... Capt. S. T. Boss..... Engr. H. J. Moorhouse
Derrick Scow The Clyde..... Capt. Engr. Ed. Wickstrom
Derrick Scow The Limit..... Capt. Engr. Ed. Anderson
Derrick Scow No. 4..... Capt. Engr.

425 Wilkins, William, Oshkosh, Wis. (Owner and Operator)

Str. Mayflower, Jr..... Capt. William Wilkins..... Engr. Dan Cronk

Willis, C. H. (See Fleet No. 223)

Willowbay Steamship Co., Ltd. (See Fleet No. 402)

426 Wilson Transit Co., The, 948 Rockefeller Bldg., Cleveland, Ohio

(Owner and Operator)

J. S. Wood, Fleet Captain.

Str. William C. Atwater.... Capt. E. R. Morton..... Engr. H. T. Meyers
Str. General Garretson..... Capt. Geo. Stewart..... Engr. Edmund Landry
Str. Charles S. Hebard..... Capt. J. J. Phillips..... Engr. J. C. Reynolds
Str. H. P. McIntosh..... Capt. L. J. Francis..... Engr. Wm. McKenzie
Str. James MacNaughton... Capt. W. F. Gardner..... Engr. Geo. E. Willard
Str. A. W. Osborne..... Capt. Michael Mausolf..... Engr. Swan Swanson
Str. W. D. Rees..... Capt. M. D. McQueen..... Engr. Alfred Henry
Str. S. H. Robbins..... Capt. W. G. Coles..... Engr. H. F. Bangs
Str. Frank E. Talpin..... Capt. John Milne. Engr. E. H. Clark
Str. J. E. Upson..... Capt. J. B. Rinn..... Engr. H. S. Wixson
Str. Capt. Thomas Wilson.. Capt. Olaf Skuggen..... Engr. F. J. Heagerty

427 Windsor & Pelee Island Steamship Co., Ltd., Pelee Island, Ont.

(Owner and Operator)

Str. Pelee Capt. J. N. Sheats..... Engr. J. R. Ferguson

428 Winkworth Transit Co., 8829 West Jefferson Ave., Detroit, Mich.

(Owner and Operator)

John Reading, Superintendent.

Str. William A. Hazard..... Capt. Russell Beattie..... Engr. Edgar Newall

429 Wisconsin & Michigan Transportation Co. (Owner and Operator)

Louis N. Biron, General Manager, F. A. Dority, Superintendent.

Str. E. G. Crosby..... (Appointments not available)

Str. Georgia (Appointments not available)

Str. Missouri Capt. F. Richardson..... Engr. C. Eason

Str. Petoskey (Appointments not available)

430 Wolverine Steamship Co., Boyne City, Mich. (Owner and Operator)

B. J. Gallagher, Vice President.

Str. Griffin Capt. J. H. Gallagher..... Engr. Fred Owen

431 Wright, Capt. Samuel, 12 Centre St., Port Arthur, Ont. (Owner and Operator)

Tug John Jr..... Capt. Sam Wright..... Engr. John Neal

432 Wyandotte Transportation Co., 1622 Ford Bldg., Detroit, Mich.

(Owner and Operator)

E. L. Ford, Port Captain, W. W. England, Superintending Engineer.

Str. Alpena Capt. George W. Moore..... Engr. Elmer Malcomson

Str. Conneaut Capt. W. H. Yates..... Engr. Justin Housten

Str. Huron Capt. C. L. Atkinson..... Engr. Neil McNeil

Str. Wyandotte Capt. J. C. McCormick..... Engr. William Rowland

Youngstown Steamship Co. (See Fleet No. 296)

433 Zenith Dredge Co., Duluth, Minn. (Owner and Operator)
A. S. McDonald, Vice President & Manager.

Tug FaylingCapt. Perry Evans.....Engr. Sam Becker
Tug Mystic(Not in commission)

Zenith Steamship Co. (See Fleet No. 387)

Ask the Red Book—

In order that the Red Book, which has served lake shipping interests continually for twenty-three years, may be of maximum value to its readers it is issued soon after navigation opens for the season. In some few cases this makes it necessary to go to press before the appointments of captains and engineers have been completed.

If you desire to have this information regarding any particular vessel or vessels and it does not appear in this book under the proper fleet, write for full information to

The Great Lakes Red Book
Penton Bldg. Cleveland, O.

CAPACITY OF ORE CARRIERS

(Gross tons on about 19 ft. draft)

*Sail or tow barge; all others steam.

†Net tons stone carrying capacity; all others gross tons.

Vessel	Gross tons	Vessel	Gross tons
Ace	2,616	Ball, F. C.	9,300
Adams, Cuyler	7,800	Barlum, John J.	7,700
Adriatic	7,500	Barlum, Thos.	8,600
Affleck, B. F.	11,400	Barnum, G. G.	8,600
Agassiz, R. L.	9,300	Barthelme	5,900
Alexander, Leslie (nee H. A. Rock)	5,500	Bay State	2,200
†Alpena	8,000	Bayton	7,500
Altadoc	6,000	Becker, W. H.	6,436
Amazon	6,000	Beechbay	1,450
Amberg, Wm. A.	9,600	Belgium	6,000
Andaste	2,200	*Bell, Sir I. L.	5,600
Anderson, John	5,300	Belvoir	3,650
Andrews, Matthew	10,000	Benmaple	2,400
Angeline	6,800	Bennington	3,000
Anticosti	3,000	Berryton	9,900
Aragon	2,100	Berwind, Edward J.	12,000
Arcturus	9,500	Bessemer, Sir H.	5,900
Arlington	2,220	Bethlehem	11,000
Ashbay	1,450	Bielman, C. F.	2,056
*Ashland	1,394	Billings, Frank	8,500
Ashley, J. S.	10,500	Birchton	2,550
Ashtabula	2,670	Black, C. A.	6,500
Atwater, W. C.	11,100	Black, H. F.	8,500
Aube	1,900	Block Joseph	10,000
*Augustus	1,285	Boardman, J. W.	5,700
Augustus, A. A.	9,000	Boland, John J.	9,850
*Aurora	2,236	Bowers, L. M.	10,500
Back Bay	3,000	Bradley, Carl D.	13,000
Bailey, F. A.	10,500	Bradley, M. A.	7,400
Baird, F. B.	1,747	Brandon	3,000
Baker, Geo. F.	10,800	Bricoldoc	6,500
Ball Brothers	7,800	Briton	3,300
		Britt, Thom.	6,000

Vessel	Gross tons	Vessel	Gross tons
Brockton	3,000	Collins, E. C.	6,600
Brookton	2,100	Colonel	5,700
Brown, Fayette	8,700	*Colpet	1,600
Brown, H. H.	9,700	*Compton	1,200
Brown, J. J. H.	7,300	†Conneaut	8,000
Brulin	3,850	*Constitution	2,339
*Bryn Mawr	6,900	Coralia	5,400
Buffington, E. J.	11,000	*Cordova	5,000
Bunsen, R. W. E.	6,800	Corey, W. E.	9,800
Burlington	3,000	*Corliss, G. H.	5,400
*Burma	1,433	Cornelius, A. E.	7,500
Butler, Jr. J. G.	10,000	Cornell	7,200
Byers, A. M.	10,000	Cort, H.	3,300
		Corvus	7,000
Cadillac	6,300	Cottonwood	3,000
Calcite	7,000	Coulby, Harry	13,800
Calgadoc	3,300	Coulee	2,800
Callender, D. E.	5,000	Covalt	2,800
Calumet	7,500	Cowle, John B.	10,500
Calverly, Jr., W. D.	5,776	Crapo	7,400
Cambria	9,000	Crawford, G. G.	11,200
Campbell, J. A.	10,000	Crawford, W. D.	8,600
Canadoc	7,000	Crescent City	5,700
Canopus	8,100	*Crete	2,083
Casco	2,370	Crete	8,500
*Case, J. I.	1,035	Croft, Harry W.	9,200
Cedarbay	1,400	Crosby, W. J.	3,000
Cedarton	2,550	Cygnus	7,000
Cetus	6,700		
Chicago Tribune	2,400	Dalhousie City	1,255
Chief Wawatam	2,990	Dalton, Henry G.	12,000
*Chieftain	5,000	Daniels, Wm. H.	1,763
Chippewa	3,150	Davidson, J.	10,800
City of Bangor	4,202	Davidson, J. E.	8,500
City of St. Ignace	1,923	Davidson, L. R.	10,000
Claremont	2,200	Davidson, Thomas	2,883
Clarke, E. A. S.	10,000	*Davie, George T.	1,100
Clarkson, Worrell	11,000	Davock, W. B.	7,300
Clement, N. P.	1,729	Denmark	8,000
Clement, S. M.	8,960	Dickson, W. B.	11,000
Clemson, D. M.	11,500	Dinkey, Alva C.	10,900
Clyde, The	1,000	Donaldson, J. A.	4,315
Cole, Thos. F.	10,900	Donnacona	12,000
Collingwood	7,000	Donner, W. H.	8,600

Vessel	Gross tons	Vessel	Gross tons
Donovan, George R.	2,800	Franz, W. C.	5,500
Douglass, E. T.	1,749	Frick, H. C.	10,100
Dundas	2,800	*Fritz, John	7,400
*Dunmore	1,070	Frontenac	12,000
Dunn, Jr., John	10,000	Fulton, Robert	5,700
Durstun, J. F.	8,000		
		Gallagher, Michael	5,141
Easton	2,200	Garretson, General	9,100
Edenborn, Wm.	7,600	Gary, E. H.	10,100
Edmonton	3,000	Gates, J. W.	7,600
Elba	7,500	Gehm, John	3,300
Elgin	2,800	Gilbert	1,108
Elmbay	1,450	Glenelg	3,000
Elwood, Isaac L.	7,800	Goodyear, F. H.	12,200
Emperor	9,000	Goulder, H. D.	9,033
Empire City	5,800	Grammer, G. J.	6,412
Ericsson, J.	5,300	Grammer, Nisbet	2,500
*Erie	1,982	*Grampian	2,200
Ewig, Harry T.	5,300	Granby	2,400
		Grand Island	8,500
Fairbairn, Sir W.	5,700	*Great Western	1,500
Fairmount	2,400	Fred W. Green	2,232
Eads, James B.	4,700	(nee Craycroft)	
Farr, M. E.	10,800	Greer, Lynford, E.	8,000
Farrell, James A.	11,000	Griffin	2,800
Fellowcraft	2,070		
Ferbert, A. H.	6,600	Hanna, D. B.	2,800
Ferris, J. E.	8,500	Hanna, Jr., H. M.	8,400
Field, A. C.	1,763	Hanna, L. C.	8,700
Field, William K.	12,000	Hart, F. W.	5,600
Filbert, W. J.	11,300	Hart, Judge	1,729
Finland	10,500	Hartwell, Fred G.	12,000
Fitch, Wm. F.	5,350	Harvard	7,100
Fitzgerald	7,500	Harvester, The	9,800
Florence	1,500	Harvey, A. F.	11,400
Fontana	5,200	Hastings	2,800
Foote, James B.	2,800	Hatfield, J. A.	11,300
Ford, Benson	10,643	Hebard, Charles S.	9,800
Ford, Emory L.	11,500	Hemlock	7,500
Ford II, Henry	10,824	*Hilda	1,000
Fort Willdoc	7,000	Hill, James J.	7,700
Foster, Parks	2,600	Hill, L. W.	9,600
Frantz, Joseph		Hobson, R.	12,000
H.	11,091	Holley, Alex.	5,600

Vessel	Gross tons	Vessel	Gross tons
Holloway, J. A.	1,745	Keyvive	1,580
Home Smith	5,500	Keywest	1,725
Hoover & Mason	8,500	*Kildonan	1,000
Houghton, D.	7,100	King	2,624
House, F. E.	11,100	*King, A. B.	1,200
Hoyt II, Elton	9,500	King, Willis L.	12,000
Hubbard, Charles	8,000	*Kingston	1,045
Hubbard, C. R.	9,400	Kinmount	2,500
Huguenot	4,000	Kinney, A. T.	10,500
Humphrey, George		Kipawa	3,300
M.	11,250	Kling, John A.	7,000
Huntley, Charles R.	1,759	Knowlton	2,400
†Huron	8,000	Kopp, Jacob T.	9,650
Hutchinson, C. L.	10,000	*Krupp, Alfred	5,400
Illinois	6,000	La Belle	8,500
India	1,800	Lackawanna	9,600
Ingalls, G. H.	7,200	Lagonda	4,900
Inland	3,000	Lakefield	2,050
Ireland, R. L.	10,500	Lake George	3,000
*Iron Cliff	2,000	Laketon	7,800
Iselin, Adrian	3,000	Lanark	2,800
Iroquois	1,182	Langell, Simon	1,200
Ishpeming	10,000	*Lapwing	1,030
		Laughlin, James	10,000
Jack	2,616	Lebanon	9,800
Jacob, C. W.	2,061	Lehigh	9,400
Jenkins, Charles		Lennox	2,800
O.	9,400	Leonard, G. B.	6,500
*Jenney, W. LeB.	5,500	Leopold, N. F.	9,500
John, J. B.	3,600	Lewiston	3,000
Jones, B. F.	10,000	*Liberty	1,400
Jones, Harry R.	7,800	Limit, The	1,600
Jupiter	5,300	Lindabury, Rich-	
		ard V.	11,500
Kenefick, Judge	1,745	Linn, W. R.	5,900
Kennedy, Hugh	10,500	Livingston	2,600
Kennedy, J. McC.	5,500	Livingstone, W.	9,576
Kerr, D. G.	11,500		
Keybar	1,723	McCullough, C. H.	10,000
Keybell	1,730	McDougall, A.	6,600
Keynor	1,806	Lynch, Thos.	10,800
Keyport	1,721	McFarland	
Keystate	1,729	(nee Reeb)	7,000

Vessel	Gross tons	Vessel	Gross tons
McGonagle, W. A.	11,500	Mills, D. O.	10,000
McIntosh, H. P.	9,100	Minch, Anna C.	6,500
McKinney, Price.	8,000	Minch, Philip	8,200
McLean, John H.	6,500	Missouri	2,434
MacNaughton, James	11,000	Mitchell, P.	6,400
MacPherson, N. B.	1,743	Mitchell, S.	2,500
MacTier, A. D.	3,000	*Mitschfibre	4,000
*Magna	5,400	Moll, Clifford F.	9,320
*Maia	6,400	*Montezuma	5,000
*Maida	3,474	*Morgan, Arthur	1,400
Maitland No. 1	2,757	Morgan, J. P.	10,700
Malietoa	7,200	Morgan, Jr., J. P.	11,000
Malton	1,920	Morrell, Daniel J.	11,000
*Manda	5,400	Morrow, J. S.	7,000
*Manila	7,300	Morse, J. C.	10,000
Mantadoc	7,000	Morse, Samuel, F. B.	7,000
Manitou	2,944	Mullen, John	2,500
Manuel, J. S.	8,500	Mullen, Martin	7,000
Maplebay	1,400	Munising	6,300
Maricopa	5,800	Munson, John G.	10,000
Mariposa	4,100	Murphy, Simon J.	6,900
Maritana	4,000		
Marquette	7,200	*Nadine	1,000
Marquette & Bes- semer No. 1	2,300	*Nasmyth, James	5,500
*Marsala	7,600	Neff, Mary K.	4,600
*Martha	5,400	Negaunee	6,300
Martian	5,300	Nelson (nee Panay)	5,600
Maryland	9,600	Neptune	5,300
Mataafa	6,600	Nettleton, A. E.	10,000
Mather, Samuel	12,000	Newbrundoc	3,300
Mather, W. G.	13,000	New York News	2,400
Mathewson	12,000	Niagara	2,300
Mathiott, E. G.	6,400	Nisbett, W. F.	1,746
Maunaloa	6,700	Norfolk	2,800
Maytham, T.	3,500	Northton	4,200
Medill, Joseph	9,000	Northumberland	1,255
*Melrose	1,232	Norton, D. Z.	7,939
*Menominee	1,000	Norway	10,000
Michigan	10,000	Nottingham, W.	6,500
Midland King	6,000	Novadoc	3,300
Midland Prince	9,000		
Miller, L. B.	8,470	Oakbay	1,450

Vessel	Gross tons	Vessel	Gross tons
Oakton	2,550	Poplarbay	1,400
Odanah	7,500	Portsmouth	5,500
O'Hagan, John J.	3,300	Presque Isle	6,600
Olcott, W. J.	11,100	Princeton	7,200
Osborn, Frank C.	4,650	Prindoc	6,000
Osborne, A. W.	5,900	Progress	2,424
Outadoc	7,000	Puritan	1,762
Oxford	2,800		
		*Quayle, Thomas	1,200
Pahlow, Louis	6,500	*Quebec	1,900
Paine, W. A.	9,000	Quedoc	4,500
Pailsley, Robert J.	5,800	Queen	2,592
Palmer, W. P.	2,700	Queen City	5,700
Palmer, W. P.	12,200		
Pargny, E. W.	11,500	Rahane	3,750
Patdoris	1,000	Rammacher, J. J.	1,723
Pathfinder	10,000	Rand, G. F.	10,500
Pegasus	6,700	Ranney, Rufus P.	6,500
Penobscot	4,272	Raprich, Wm. F.	6,500
Pere Marquette 12	2,767	Ream, N. B.	10,700
Pere Marquette 14	2,531	Redfern, C. E.	1,400
Pere Marquette 15	2,443	*Reddington, Nellie	1,083
Pere Marquette 17	2,775	Reed, James H.	7,800
Pere Marquette 18	2,777	Rees, W. D.	5,400
Pere Marquette 19	2,626	Reiss, Clemens A.	7,000
Pere Marquette 20	2,626	Reiss, J. L.	9,000
Pere Marquette 21	2,992	Reiss, J. P.	10,000
Pere Marquette 22	2,985	Reiss, Otto M.	7,000
Perkins, G. W.	10,000	Reiss, Peter	10,000
Perseus	8,100	Reiss, Richard J.	7,000
Petcol	3,700	Reiss, Wm. A.	7,000
Philbin, D. M.	8,600	*Reliance	3,000
Phipps, Henry	10,600	Rensselaer	7,200
Pickands, Colonel James	12,000	Richards, J. B.	1,743
Pillsbury, J. S.	1,754	Richardson, R. R.	6,500
Pinebay	1,450	Richardson, W. C.	6,647
Pioneer	9,500	Riverton	7,800
Pittsburgh	1,000	Robbins, F. J.	4,222
Poe, Gen. O. M.	7,200	Robbins, S. H.	6,800
Pollock, W. G.	4,872	Roberts, Jr., P.	11,200
Pomeroy, R. W.	1,723	Roberts, W. T.	10,000
Pontiac	12,000	Robinson, C. S.	9,600
Pope, E. C.	2,878	Robinson, L. W.	3,000
		Robinson, T. W.	11,000

Vessel	Gross tons	Vessel	Gross tons
Rockefeller, F.	4,600	Smith, L. C.	10,000
*Roebing, J. A.....	7,400	Smith, M. C.....	6,500
Rogers, H. H.....	10,700	Smith, W. L.	6,500
Rosemount	2,250	Snyder, Jr., W.	
Roumania	1,837	P.	12,200
Royalton	12,000	Sonoro	3,914
		Soodoc	7,000
Sacramento	3,000	Sprucebay	1,400
*Sagamore	3,250	Squire, F. B.....	6,500
Sainte Marie.....	2,383	Stackhouse, P.....	8,600
Sandcraft	2,054	Stanton, John	9,500
Sandmaster	2,018	Starmount	2,400
Saskadoc	7,000	†Steel Chemist.....	2,100
Saturn	6,700	†Steel Electrician..	2,100
Saucon	9,900	†Steelmotor	2,100
Saunders, Jr., Ed-		Steelton	2,100
win N.	8,900	†Steelvender	2,500
Schiller, W. B.....	10,900	Steinbrenner, H...	6,500
Schneider, A. E.		Stephenson, G.	5,900
R.	8,000	Stewart, D.	2,500
Schneider, Cletus..	5,800	Stewart, Graeme..	9,000
Schoonmaker, Col.		Stewart, James ...	1,759
Jas. M.	12,200	Stifel, Wm. F.....	6,743
Schwab, Charles		Stone, Amasa	9,600
M.	12,000	Sullivan, J. J...	10,500
Scranton	3,000	Sultana	3,914
Seither, Frank.....	4,872	Sweden	7,000
Sellwood, Joseph..	9,600	*Swederope	2,300
Senator	6,000		
Shaughnessy, Sir		Taplin, Frank E.	6,900
T.	8,500	Taurus	6,700
Shaw, H. L.	7,000	Taylor, B. H.....	10,000
Shaw, Quincy A..	8,700	Taylor, J. Frater	5,500
Sheadle, J. H.....	10,000	Ten	2,015
Shenango	11,000	*Thomas, S. G.....	5,500
Sherwin, John	9,500	Thompson, C. A.	9,600
Shiras, McG.....	6,600	Thompson, D. P...	10,750
Siemans, Sir Wm.	6,000	Thompson, Smith	8,000
Sierra	6,900	Tomlinson, G. A.	9,000
Simcoe	2,800	Torain, G. L.....	1,754
Simpson, Jos. W.	2,400	Thordoc	3,300
*Smeaton, John.....	7,600	Topping, John A..	11,319
Smith, B. Lyman	6,500	Townsend, E. Y.	11,000
Smith, H. W.	7,000	Tremaine, M. S...	7,000

Vessel	Gross tons	Vessel	Gross tons
Trevisa	1,812	Watt, James	5,900
Trimble, Richard	11,200	Way, S. B.	5,300
Truesdale, W. H.	7,300	Weavercoal	1,500
Turner, J. J.....	9,200	Weed, Shelton	1,745
Turret Cape	2,850	Werner, H. P....	5,700
Turret Court	2,950	West, Charles C.	8,000
Twin Cities	1,460	Westland	3,100
Twin Ports	1,460	White, Peter	9,500
*Tyrone	4,200	White, W. F.....	10,000
		Wiarion	2,100
Uhrig, Alex B.....	5,000	Wickwire, T. H..	9,150
Uhrig, E. A.	9,300	Wickwire, Jr., T.	
Upson, A. S.	8,800	H.	10,000
Upson, J. E.	8,700	Widener, P. A.	
Usona	2,000	B.	10,600
		Williams, Homer	
Valcartier	5,500	D.	11,500
Vandoc	7,000	Willowbay	1,400
Vega	6,800	Wilson, G. N.....	7,000
Venus	5,300	Wilson, Capt. T..	6,500
Verona	8,500	Windoc	7,000
Victory	7,000	*Witbeck, Henry...	1,080
Viking	1,500	Wolf, Wm. H.....	10,000
Vinmount	3,100	Wolvin, A. B.....	10,000
		Wood, Joseph	8,600
Wahcondah	2,200	†Wyandotte	8,000
Wallace, J. C.....	10,000		
Wallace, Robert		Yates, Harry	10,000
B.	11,000	Yorkton	2,200
Walsh, J. P.....	8,547	Yosemite	5,600
Walters, Thos.....	12,000	Youngstown	12,000
Warner, W. H.....	10,800	Yukondoc	3,300
Waterloo	2,800		
Waterton	2,600	Zenith City	5,300
Watson, C. W....	5,600	Ziesing, August...	11,400

Directory of Shipbuilding and Ship Repair Yards Serving Shipping on the Great Lakes

American Boiler Works

Front & State St., Erie, Pa.

F. J. Tollon, President and General Manager.
F. J. Tollon Jr., Chief Engineer.

REPAIR FACILITIES: Equipment for all boiler and engine repairs. Equipment for any hull work above water line. (No dry dock.)

FLOATING REPAIR EQUIPMENT: Tug with air compressor and electric welding outfit. Derrick scow with 45 foot boom.

GENERAL INFORMATION: Builders of tugs and scows.

The American Ship Building Co.

Foot of West 54th St., N. W., Cleveland, Ohio.

A. G. Smith, President.

J. L. Wallace, Assistant to President.

James E. Davidson, Vice President and Treasurer.

W. H. Gerhauser, Vice President and Secretary.

G. C. Sheidler, Assistant Secretary and Assistant Treasurer.

A. W. Cross, Naval Architect.

J. C. Workman, Chief Engineer.

CLEVELAND PLANT

A. C. Payton, Superintendent of Shipyard.

George Waterbury, Superintendent of Machine and Boiler Shops.

BUILDING BERTH: One; maximum size of ship, 750 feet.

REPAIR FACILITIES: Facilities for making repairs of all kinds to both wood and steel hulls and also machinery—foundry; machine shop; boiler shop; sheet metal shop; pipe shop; joinery shop; electrical shop; pattern shop; etc.

DRY DOCKS: No. 1—Length over all, 547' 0"; width of entrance at top, 65' 0"; depth over sill, 12' 8".

LIMITING CONDITIONS: No limiting conditions for a vessel's entry to plant.

FLOATING REPAIR EQUIPMENT: Consists of a steam derrick scow of 10-ton lift and a barge, both equipped with air compressors, electric welding outfits, etc.

GENERAL INFORMATION: Complete stocks carried of propeller blades, grate bars, furnace fittings, auxiliary machinery parts, etc.

LORAIN, OHIO, PLANT

John E. Steinman, General Superintendent.

BUILDING BERTHS: Four; two for ships up to 735 feet, and two for ships up to 550 feet.

REPAIR FACILITIES: Facilities for making repairs of all kinds to both wood and steel hulls, and also machinery—machine shop; boiler shop; sheet metal shop; pipe shop; joinery shop; electrical shop; heavy forging shop; etc.

DRY DOCKS: No. 1—Length over all, 586' 0"; width of entrance at top, 66' 0"; depth over blocks, 14' 6".

No. 2—Length over all, 736' 0"; width of entrance at top, 80' 0"; depth over blocks, 14' 6".

LIMITING CONDITIONS: No limiting conditions for a vessel's entry to plant.

FLOATING REPAIR EQUIPMENT: Consists of a barge equipped with air compressor, electric welding outfit, etc.

GENERAL INFORMATION: Complete stocks carried of propeller blades, grate bars, furnace fittings, auxiliary machinery parts, etc.

Thomas B. Banner Boiler & Welding Co.

308 West Austin Ave., Chicago, Ill.

John L. Banner, President.

GENERAL INFORMATION: Have repair facilities to do plate work above water line. Do any kind of boiler and welding work.

Buffalo Dry Dock Co.

(Subsidiary of The American Ship Building Co.)
191-301 Ganson St., Buffalo, N. Y.

L. H. Reynolds, Superintendent.

REPAIR FACILITIES: Facilities for making repairs of all kinds to both wood and steel hulls and also machinery—machine shop; sheet metal shop; pipe shop; joinery shop; electrical shop; etc.

DRY DOCKS: No. 1—Length over all, 470' 0"; width of entrance at top, 61' 0"; depth over blocks, 13' 6".

No. 2—Length over all, 630' 0"; width of entrance at top, 79' 3"; depth over blocks, 13' 10".

No. 3—Length over all, 401' 0"; width of entrance at top, 53' 0"; depth over blocks, 14' 6".

LIMITING CONDITIONS: Vessels up to 600 feet keel will swing in river.

FLOATING REPAIR EQUIPMENT: Consists of a steam derrick scow of 10-ton lift and a barge, both equipped with air compressors, electric welding outfits, etc.

Canadian Vickers, Limited

Maisonneuve, Montreal, Canada

George Barr, Managing Director.

J. W. Savidant, Secretary and Treasurer.

H. H. German, Manager Marine and Aviation Department and Naval Architect.

REPAIR FACILITIES: Fully equipped to handle any vessel coming to Montreal.

BUILDING BERTHS: Six; length 500 feet.

DRY DOCK: One floating dock, 600 feet long, operated in one or two sections.

Chicago Ship Building Co.

(Subsidiary of The American Ship Building Co.)
101st St. & Calumet River, South Chicago, Ill.
John Sinclair, Superintendent.

REPAIR FACILITIES: Facilities for making repairs of all kinds to both wood and steel hulls and also machinery—machine shop; electrical shop; etc.

DRY DOCKS: No. 1—Length over all, 570' 0"; width of entrance at top, 71' 8"; depth over blocks, 15' 0".

No. 2—Length over all, 727' 4"; width of entrance at top, 90' 2"; depth over blocks 16' 0".

LIMITING CONDITIONS: No limiting conditions for a vessel's entry to plant.

FLOATING REPAIR EQUIPMENT: Consists of 4 self-propelled repair boats; 1 derrick scow.

Collingwood Shipyards, Limited

Collingwood, Ont., Can.

H. B. Smith, President.

John S. Leitch, Vice President and General Manager.

J. J. Swan, Naval Architect.

F. E. Courtice, Chief Engineer.

J. Dalrymple, Superintendent.
E. Podmore, Purchasing Agent.

REPAIR FACILITIES: Fully equipped for all kinds of repairs to steel or wooden vessels—engines, boilers and auxiliaries.

BUILDING BERTHS: Five.

DRY DOCKS: No. 1—518' by 56' 0" at entrance.

No. 2—412' by 95' 0" at entrance.

LIMITING CONDITIONS: 16' 0" draught.

Davie Shipbuilding & Repairing Co., Ltd.

Lauzon, Levis, Que., Canada

REPAIR FACILITIES: Hull repairs to vessels of any size. Average engine repairs.

BUILDING BERTHS: Two for 600 foot ships. Four for small craft.

DRY DOCKS: No. 1—1150' by 120' by 40' on sill.

No. 2—600' by 62' by 24' on sill.

Detroit Shipbuilding Co.

(Subsidiary of The American Ship Building Co.)
 Foot of Orleans St., Detroit, Mich.

John D. Langell, Superintendent.

REPAIR FACILITIES: Facilities for making repairs of all kinds to both wood and steel hulls and also machinery—machine shop; sheet metal shop; pipe shop; joinery shop; electrical shop; etc.

DRY DOCK: No. 1—Length over all, 367' 7"; width of entrance at top, 78' 0"; depth over sill, 15' 6".

LIMITING CONDITIONS: No limiting conditions for a vessel's entry to plant.

Great Lakes Boat Building Corp.

Office & Yard

3250 N. Washtenaw Avenue
 North Branch of Chicago River
 Chicago, Ill.

Henry C. Grebe, President.

L. F. Baker, Treasurer.

H. D. Rice, Naval Architect

Complete facilities for building and repairing yachts and commercial boats.

Operating 100 ton Marine Railway.

Great Lakes Engineering Works

River Rouge, Mich.

J. A. Ubsdell, President and General Manager.

George B. Turnbull, Vice President.

John T. Webster, Vice President.

Frederick G. Morley, Secretary-Treasurer.

Dwight True, Naval Architect.

Howard M. Varian, Chief Engineer.

C. E. Baisley, Superintendent.

REPAIR FACILITIES: Complete for ship, engine and machinery repairs.

BUILDING BERTHS: Three; 800 foot ship.

DRY DOCKS: No. 1—Steel floating dock, 626' o. a.

No. 2—Steel floating dock, 162' o. a.

DETROIT, MICHIGAN, PLANT

Robert Jackson, Superintendent.

REPAIR FACILITIES: Complete for engine and machinery repairs.

ASHTABULA, OHIO, PLANT

F. C. Pahlow, Superintendent.

REPAIR FACILITIES: Complete for ship, engine and machinery repairs.

BUILDING BERTHS: One; 800 foot ship.

DRY DOCK: Concrete dock, 650' over all.

The Great Lakes Towing Co.

General Office

1060 Union Trust Bldg., Cleveland, Ohio
Yard

Foot Jefferson St., Cleveland, Ohio

H. E. Gilpin, President.

G. A. Tomlinson, Vice President.

H. N. Hobart, Assistant to the President.

M. H. Wardwell, Secretary and Treasurer.

REPAIR FACILITIES: Repairs on either steel or wooden tugs and other small craft either steel or wood hulls. Also to machinery or boilers in vessels.

DRY DOCKS: Floating dry dock 80 feet long, with minimum clearance between the towers of 33 feet.

LIMITING CONDITIONS: Can dock tugs and small craft not exceeding the dimensions given above and drawing not more than 12 feet of water.

The Kingston Shipbuilding Co., Ltd.

KINGSTON, ONTARIO, PLANT

H. C. Welch, Superintendent.

REPAIR FACILITIES: Fully equipped for all kinds of repairs to steel or wooden vessels—engines, boilers and auxiliaries.

BUILDING BERTHS: Two.

DRY DOCK: No. 1—300' by 55' 0'' at entrance.

LIMITING CONDITIONS: 16' 0'' draught.

Manitowoc Ship Building Corp.

Manitowoc, Wis.

Charles C. West, President.

L. E. Geer, Vice President and Treasurer.

A. P. Rankin, Vice President, Chief Engineer.
W. L. Wallace, General Manager and Naval Architect.

A. L. Pitz, Superintendent (Shipyard).

W. I. McIntosh, Superintendent (Machine Shop).

J. J. Norris, Superintendent (Boiler Works).

REPAIR FACILITIES: Full facilities for boiler, machinery and hull repairs.

BUILDING BERTHS: Three; 600 feet.

DRY DOCKS: No. 1—Graving dock, 300' by 47' 5''.

No. 2—Floating dock, 600' by 76' 0''.

GENERAL INFORMATION: Maintain complete facilities for all classes of ship repairs, also furnishing of stores and supplies.

Marine Iron & Ship Building Co.

Foot of 11th Ave., West Duluth, Minn.

M. Christianson, President.

John Abernethy, Vice President and Chief Engineer.

John Geistman, General Manager and Secretary.

Robert Auld, Naval Architect.

Swan Larson, Superintendent.

REPAIR FACILITIES: Hull and engine.

BUILDING BERTHS: Two; 300 feet.

DRY DOCKS: Floating, 1500 ton.

Midland Shipbuilding Co., Ltd.

Midland, Ont., Can.

W. H. Coverdale, President.

T. R. Enderby, Vice President.

R. B. Thomson, Secretary.

J. I. Hobson, Treasurer.

James Wilkinson, General Manager.

James McLachlan, Naval Architect.

Arthur B. Clark, Chief Engineer.

Hector McLeod, Superintendent.

REPAIR FACILITIES: Fully equipped for boiler or engine repairs.

BUILDING BERTHS: One at 650' or two at 265'.

Milwaukee Dry Dock Co.

(Subsidiary of The American Ship Building Co.)

Foot of Washington St., Milwaukee, Wis.

W. H. Gerhauser, Vice President.

John Sinclair, Superintendent.

REPAIR FACILITIES: Facilities for making repairs of all kinds to both wood and steel hulls and also machinery.

DRY DOCK: No. 1—Length over all, 445' 6"; width of entrance at top, 61' 0"; depth over sill, 13' 0".

LIMITING CONDITIONS: No limiting conditions for a vessel's entry to plant.

Port Arthur Shipbuilding Co., Ltd.

Port Arthur, Ont., Can.

A. B. Conmee, Manager and Secretary-Treasurer.

L. E. Tornroos, Naval Architect and Chief Engineer.

B. H. Saunders, Superintendent.

REPAIR FACILITIES: Complete facilities for repairs to engines, boilers and auxiliaries.

BUILDING BERTHS: Two, 650' long.

DRY DOCK: One, 700' long, 98' wide. Water over sill at normal lake level 16'.

GENERAL INFORMATION: The only dry dock on the Canadian side of the Great Lakes that can dock a vessel of 550' or over.

Sturgeon Bay Shipbuilding & Dry Dock Co.

Sturgeon Bay, Wis.

BUILDING BERTHS: Three.

DRY DOCKS: No. 1—100'.

No. 2—70'.

No. 3—220'.

The Superior Shipbuilding Co.

(Subsidiary of The American Ship Building Co.)

Grand Ave., N. E., Corner 2d St., Superior, Wis.

R. J. Close, Superintendent.

REPAIR FACILITIES: Facilities for making repairs of all kinds to both wood and steel hulls and also machinery.

DRY DOCKS: No. 1—Length over all, 609' 0"; width of entrance at top, 66' 0"; depth over sill, 13' 6".

No. 2—Length over all 620' 0"; width of entrance at top, 66' 6"; depth over sill 17' 6".

LIMITING CONDITIONS: No limiting conditions for a vessel's entry to plant.

FLOATING REPAIR EQUIPMENT: Consists of a steam derrick scow of 10-ton lift, equipped with air compressor, electric welder, etc.

Toledo Shipbuilding Co., Inc.

Toledo, Ohio

H. S. Wilkinson, President and Treasurer.

E. Hopkins, Vice President and Naval Architect.

J. Burton Ayers, Secretary and Assistant Treasurer.

J. F. Rawlinson, General Superintendent.

J. L. Goble, Chief of Hull Department.

J. O. Crafts, Chief of Machinery Department.

REPAIR FACILITIES: Complete facilities for building and repairing all kinds of steel vessels, their engines and boilers, also the auxiliary machinery.

BUILDING BERTHS: Three, capacity for vessels up to 650 feet in length.

DRY DOCKS: No. 1—Concrete with steel gate, length 690 feet, width 96 feet, depth over sill 14' 6".

No. 2—Wood, with steel gate, length 569 feet, with 80 feet, depth over sill 13' 0".

In the Race for Speed *Oertz Streamline Rudder* Narrows the Lakes!

A ship owner cannot afford to overlook any device that can shorten sailing time and give him every modern advantage of speed in keen competition. Saved time means more sailings—more cargo per ship per year—more return on investment in ships.

Oertz Streamline Rudder, in actual tests, has increased speed 6-13%, or correspondingly reduced S.H.P. 8-15%. It saves time and fuel by reducing resistance and completely eliminating yawing.

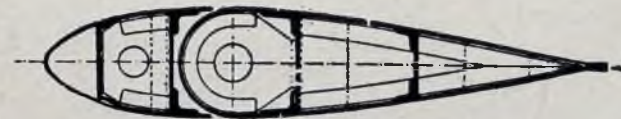

Cross section, midship position

<p>30-50% less steering engine power required. No rudder tackles needed even in heaviest weather; strong vibration in stern practically eliminated; steerability improved; turning radius less than half that of standard rudder.</p>	<p>Two parts—a fixed forepart about $\frac{1}{3}$ the length and a movable rear part—with the greatest thickness at the pintles afford minimum resistance to the waterflow and greatest pressure sideways (steering power).</p>
---	--

OERTZ STREAMLINE RUDDER CORP.
75 West St., New York City

Port Directory and Where-to-Buy

ALLOUEZ, WIS.

Supplies (Marine)—DULUTH MARINE SUPPLY CO. (A. R. Hallam & K. E. Hallam) Captains', Engineers' and Stewards' Supplies—Vacuum, Erie, Standard and Enarco Oils. Phones: East 54—East 347.

ASHTABULA HARBOR, O.

Clothing Store—KARPEL, MAX, THE, Clothing and Furnishings; Sailors' Supplies. "The House that treats you right."

Drugs—TURNER'S DRUG STORE, 99 Bridge St. Specialty Ship Medicine Chests replenished.

Laundry—ELECTRIC LAUNDRY CO., THE, Cor. Market and Joseph Streets.

Meats—RENNICK, TOM J., 98 Bridge St., Cor. Hulbert. Meats and Ice. Special Attention to marine trade. Phone No. 338.

Repairs—MCKINNON IRON WORKS CO., THE. Oil and Engineers' Supplies. Machine Shop, Foundry, Grate Bars.

Repairs—GEARY BOILER WORKS, Columbus Street. Boiler Work. Expert Electric Welding. Floating Shop.

Sailors' Supplies—WHITRIGHT, H. A., The "Bum" Boat. The store that comes to you.

Supplies—CHRISTENSEN, WILLIAM, 70 Bridge St. Cigars and Tobacco, Magazines, News, Ice Cream, Sodas, etc.

BROOKLYN, N. Y.

Life Boats—LANE, C. M., LIFE BOAT CO. INC., 856 Humboldt St. Life Rafts—Life Floats.

MAIN OFFICE
Haymarket 0608—0609

NIGHT TELEPHONES
Sheldrake 9199
Haymarket 0608

**DAY and NIGHT
SERVICE**

MARINE BOILER REPAIRS and GENERAL SHIP HULL REPAIRS

Only Expert and Dependable Workmen Employed by Us All Insured and Bonded.

Portable Equipments	Hand Equipments
Electric Welders	Retubing Tools
Oxy-Acetylene Welders	Staybolt "
Air Compressors	Flanging "
Electrical Hoisting	Riveting "
	Drilling "

Boilermaking, Steel Plate Construction Engineers, Smoke Stacks, Smoke Breechings, Water and Oil Tanks, Coal and Ash Hoppers, Bunkers, Jacketed Kettles.

COMMONWEALTH BOILER REPAIR CC.

Wm. J. Corbett, Prop.

Formerly President of Geo. E. Corbett Boiler & Tank Co.

806 W. Washington Blvd.

Chicago, Ill.

Branch in South Chicago

BUFFALO, N. Y.

Attorneys at Law—SANDERS, DUDLEY & CONNELLY, 1142 Marine Trust Bldg.

Boilers—OLDMAN AND MAGEE BOILER WORKS, INC., 32-34 Illinois St. Marine work a specialty. Electric Welding. Boiler Repairing, day or night.

Boiler Compounds—LAKE ERIE MANUFACTURING CO., INC., 192-198 Chicago St.

Electric Welding—TASHENBERG BROS. BOILER WORKS, 43-47 Illinois St. Office phone Seneca 1307. Night phone Jefferson 0946 R.

Groceries—GUNN, P. J., 60 Michigan Ave.

Meats—GEHM, JOHN, 1-3-4-5-7 Elk St. Dealer in choice meats of all kinds. Phones: Bell 1204; Seneca 21134.

Packing—ANCHOR PACKING COMPANY, Andrews Bldg. Phone: Seneca 5258.

Proctors in Admiralty—BROWN, ELY & RICHARDS, 1317 Chamber of Commerce.

Propellers—TROUT, H. G., CO., (King Iron Works), 226 Ohio St.; Propeller Wheels, Marine Engines, Brass and Iron Castings. Large variety of Grate Bars in Stock. Phones: Seneca 5361.

Ranges (Galley)—RUSSELL & WATSON, INC., 94-96 Pearl St.

Repairs—FORD BROTHERS, 23-29 Illinois St. General Machinists. Cylinders and Valves Bored in position. Expert repairing and all kinds of Ice Machines. Phone: Seneca 4677.

Repairs—FRONTIER ENGINE WORKS, INC., Office and works: 11 Perry Street near Main. Marine repairing our Specialty. Manufacturers of Sutton Marine Engines and propeller wheels. Also Agents for Cassco Packing. Bell Phone. Seneca 3007. Night phones: Joseph A. Kirsch, 51 Northumberland Ave., Filmore 8190-J, and Frank C. Wolf, 308 Hickory St., Jefferson 4167-R.

Repairs—NAGLE & O'DAY, 176-190 Ohio St. General repair and jobbing machine work. Brass, Iron and Steel Castings. Phone Seneca 3500.

Day Phone
Diversey 3583

Night Phone
Irving 0250

Rosner Boiler Works

F. R. Rosner, Prop.

Boiler Repairs
day or night

Boilers, Tanks, Breechings
Smoke Stacks, etc.

Special Attention Given
to Repair Work

Electric & Acetylene
Welding & Cutting

Marine Work a Specialty

Office and Works:
1520-1522 N. Halsted St., Chicago, Ill.

BUFFALO, N. Y.—Continued

Repairs—NICHOLSON & HALL BOILER & WELDING CORP., Office—178 Ohio St. Boilers, Tanks and Stacks repaired. All kinds of Electric Welding, Marine work a specialty. Phone, Seneca 3500.

Shipbuilders—BUFFALO DRY DOCK COMPANY, 191-301 Ganson St. Telephones: Seneca 4055 and 4056.

Ship Chandler—BAKER, HOWARD H. & C., 18-26 Terrace. We are distributors for Whitlock Cordage. Phone Seneca 5967.

CHICAGO, ILL.

Boiler Compound—GARRATT-CALLAHAN COMPANY, 310 South Michigan Ave. Stops corrosion, pitting and minor leaks.

Marine Auxiliaries—GRISCOM-RUSSELL CO., THE, 835 B—Monadnock Bldg.

Packing—ANCHOR PACKING COMPANY, 200 E. Illinois Street. Phone: Superior 5249.

Packing—CASSCO BAR-METALLIC PACKING CO., 3559 Lincoln Ave. Cor. Addison St.

Packings—GARLOCK PACKING CO., THE, 600 West Jefferson Blvd.

Refrigeration—MIDWEST ENGINEERING & EQUIPMENT CO., 617 Fulton St. Sales and Service Representatives for Frick Refrigerating and Ice-Making Machinery.

Repairs—COMMONWEALTH BOILER REPAIR CO., 806 W. Washington Blvd.

Repairs—ROSNER BOILER WORKS, 1520-1522 N. Halstead St. Electric and Acetylene Welding and Cutting.

Rubber Goods—QUAKER CITY RUBBER CO., 217 West Huron St. Phone, Dearborn 1914-1915-1916. Also P. P. P. Rod Packing, Ebonite Sheet Packing, Ebonite Stop Valve Packing and Pump Valves. Hose for all purposes.

Welding—BANNER, THOMAS B., BOILER & WELDING CO., 308 W. Austin Ave.

CLAYTON, N. Y.

Coal and Oil—CONSAUL-HALL CO., INC.

W. B. Boom, Pres. and Gen'l Mgr.

Telephones:

Superior 2695; Night—Evergreen 2140-J,
Lakewood 6304-W

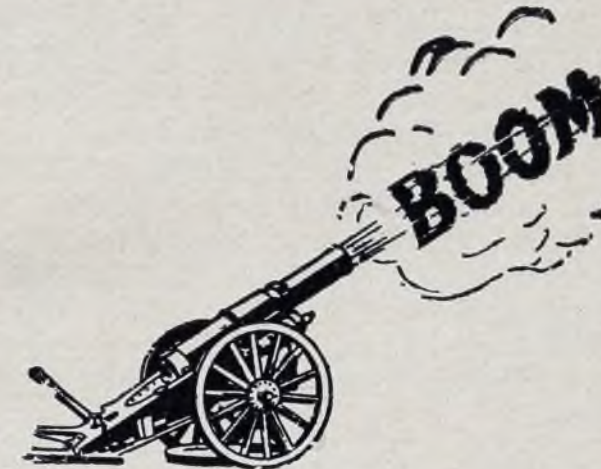
**THE BOOM BOILER AND WELDING CO.**

33 Electric Welding Plants

Complete Equipment on Motor Trucks
and Floating Plants

Boiler Makers, Steel Plate
Construction Work

Oxy-Acetylene Welding and Cutting
Thermit Welding Machinist.

Marine Repairs A Specialty
ANY PLACE—ANY TIME

Main Office and Plant No. 1
Main and Elm Streets
CLEVELAND, O.

CLEVELAND, O.

- Architects (Marine)**—SMITH BROTHERS, 754 Rockefeller Bldg. Marine Architects, Surveyors and Appraisers.
- Bank**—CENTRAL NATIONAL BANK, 308 Euclid Ave.
- Bank**—SOCIETY FOR SAVINGS, Public Square.
- Boilers**—BOOM BOILER AND WELDING COMPANY, THE, Main Office and Plant No. 1, Main & Elm St. Boiler Makers.
- Boiler Chemicals (Red Star)**—THOMPSON-HAYES CO., THE, Sole Marine Agents, Lake Erie Manufacturing Co., Inc., 821-3 Rockefeller Bldg. Phone MAIN 0320.
- Boiler Compound**—BROOKS OIL CO., THE, Brooks Boiler Metal Treatment removes and prevents scales, stops rusting, pitting and corrosion.
- Books**—PENTON PUBLISHING CO., THE, (Book Department) Penton Bldg., Lakeside and W. 3rd St. We can supply any book in print.
- Coal**—IRONVILLE DOCK & COAL CO., THE, 1300 Leader Bldg.
- Coal**—PICKANDS, MATHER & CO., Union Trust Bldg.
- Coal**—PITTSBURGH COAL COMPANY, Terminal Tower Bldg.
- Dry Goods**—FRIES & SCHUELE, THE, West 25th St. Beddings, Linens, Curtains and Floor Coverings. Phone LINcoln 4340.
- Dry Goods**—ROOT & McBRIDE CO., 1250 West 6th St.
- Furniture (Steamboat)**—LEOPOLD BROTHERS FURNITURE COMPANY, Lorain at W. 30th Street. Phone MELrose 2324.
- Gauges**—CLEVELAND STEAM GAUGE CO., 1100 W. 9th St. Gauge manufacturers. We repair gauges and valves of every description.
- Heaters and Purifiers (Feed Water)**—WALLENE ENGINEERING CO., 1783 E. 11th, Great Lake Representative for Davis Engineering Corporation, 90 West St., New York City.

Thomas B. Banner Boiler & Welding Company

Plate Work

Boiler Repairing

Machinists

Electric &

Acetylene Welding

Engineers' Supplies

Day Phone: Superior 7269

Night Phone: Buckingham 2821

“ “ Lakeview 2498

Chicago, Ill.

308 W. Austin Ave.

CLEVELAND, O.—Continued

- Laundry**—REAL FAMILY LAUNDRY CO., 5710 Superior Ave. RANDolph 0218.
- Lubricants**—NATIONAL REFINING CO., THE, National Bldg. Marine Oils.
- Lubricants**—WELSH OIL CO., 3277 Washington Blvd. Phone: FAirmount 1941.
- Packing**—ANCHOR PACKING COMPANY, 1376 E. 17th Street. Phone: PROspect 2748.
- Packings**—CRANDALL PACKING CO., THE, 1637 Superior Ave. Phone: SUperior 1077.
- Packings**—GARLOCK PACKING COMPANY, THE, Marion Bldg. Phone: MAIn 0310.
- Paints (Marine)**—FERBERT-SCHORNDORFER CO., Elmwood Ave. & Berea Rd.
- Proctors in Admiralty**—GOULDER, WHITE & GARRY, 1682 Union Trust Bldg.
- Proctors in Admiralty**—KELLEY, DAVID & COTTRELL, 1968 Union Trust Bldg.
- Provisions**—HAUSHEER & SONS CO., THE, 1220-1228 W. 11th St., 128-32 Dock. Meats, groceries, vegetables, fruits and ship supplies.
- Refrigeration**—PHOENIX ICE MACHINE CO., THE, 2711 Church Ave., N. W. Phone: SUperior 2346.
- Repairs**—RUD MACHINE CO., THE, 1036 W. 11th St. Phone: CHerry 0658.
- Shipbuilders**—AMERICAN SHIP BUILDING CO., THE. Foot of W. 54th St., N. W. Phone: EVergreen 2280.
- Soaps**—HARVARD MANUFACTURING CO., 4307 Woodbine Ave.
- Supplies**—THOMSON, J. & A., 1232 W. 11th St. Marine Supplies.
- Supplies**—UPSON-WALTON CO., THE, 1294-1310 W. 11th St.
- Welding**—BOOM BOILER & WELDING CO., THE, Main office and Plant No. 1, Main and Elm Sts.

CONNEAUT, O.

- Packing**—CONNEAUT PACKING CO., THE,

Office phone: Seneca 1307

TASHENBERG BROS. BOILER WORKS

43-47 Illinois St., BUFFALO, N. Y.

Expert Boiler and Hull Repairing
Floating electric welding and air plants.

DAY & NIGHT SERVICE

After 4:30 P. M. Phone Jefferson 0946 R

Phones: 290-1217

PIONEER BOILER WORKS

BRUCE M. WRIGHT, Mgr.

TANKS STACKS

Boiler Repairing — Electric Welding

Day and Night

PORT HURON, MICH.

DETROIT, MICH.

Boilers—ACME BOILER WORKS, INC., Junction at W. Jefferson Ave. Boilermakers. Phone: Cedar 1148-1149. Nights & Sundays Longfellow 3244, Fairmount 5341W.
Packing—ANCHOR PACKING COMPANY, 251 Larned Street, W. Phone: Randolph 4975.
Packings—GARLOCK PACKING CO., THE, 3-250 General Motors Bldg.
Shipbuilders—DETROIT SHIPBUILDING COMPANY, Foot of Orleans St. Telephone: Randolph 6900.

DULUTH, MINN.

Attorneys—SPENCER & SPENCER, 1103 Alworth Bldg., Marine Law.
Electric Service, Supplies and Repairs—BENSON ELECTRIC CO. We manufacture electric whistles, steering devices and rudder indicators and give day and night service on all electrical work. Telephone repairs a specialty. Phones: Broad 1123; Nights, Broad 1874 or Broad 1926.
Ship Repairs—MARINE IRON & SHIPBUILDING CO. Telephone: Melrose 735-6-7.
Supplies—DULUTH MARINE SUPPLY CO., Foot of Fifth Ave. West.

EAST AURORA, N. Y.

Boiler Compound—WAKEFIELD BOILER COMPOUND CO., 667-669 Oakwood Ave.

ELYRIA, O.

Packings—MARTELL PACKINGS CO. Complete and prompt packing.

ERIE, PA.

Coal—ANCHOR COAL COMPANY, Foot of Holland St.
Provisions—MEISER, FRED C., 29 East 7th St. Fresh, Salt, Smoked Meats and Fish. Ice, Milk and Poultry. Phone: 42-196. Res. Phone: 43-487.

John T. Kaine, Prop. Telephone 654 W

Kaine Boiler & Machine Works

Electric Welding

DAY or NIGHT

We are equipped to give you prompt service.

Expert Licensed Welders.

All workmanship guaranteed.

Competent Boilermakers for your
Boiler troubles.

326 Court Street
Opp. Court House Sault Ste. Marie, Mich.

Telephone Broadway 380 Night call: West 3616
Hopkins 3157 J

THE MERTES-MILLER CO.

Marine Boiler Works

BOILERS, TANKS and SHEET IRON WORK
"ELECTRIC WELDING"

Repair Work a Specialty

239-241 PITTSBURGH AVE., MILWAUKEE, WIS.

THE RUD MACHINE COMPANY

1036 W. 11th St.
CLEVELAND, OHIO

All Hull repairs above water line.
All kinds of boiler and machine work.
Derrick scow and welding boat.

Telephone: Cherry 0658.

ERIE, PA.—Continued

Repairs—AMERICAN BOILER WORKS, Front & State Sts., Electric Welding, Boiler, Engine and Hull Repairing. Day and night Service.

Repairs—ERIE MACHINE SHOPS, 13th and Peach Sts. Boiler and Engine Repairs; Electric Welding; General Machine Work of all kinds. Day and Night Service. Both Phones.

Repairs—FICKENWORTH, G., Front & State Sts. Boiler Repairing, Forging and Electric Welding. Shop Phone C-51-943, Residence Phone 55-177.

Repairs—NATIONAL BOILER WORKS, Foot of Peach St. Boiler and Hull Repairing. Blacksmithing, Electric and Acetylene Welding. Phone: Mutual 23-846; Night and Sunday calls 75-225.

Sheet Metal Work—McGINIS, E. H., Foot of French St.

Supplies—BECKMAN, HENRY, & SON, 506 State St. Groceries and Ship Chandlery. Mutual Phone 24164.

Supplies (Engineers')—BREBNER, A. H., & SON, 16 E. 5th St. Paints, Oils, Varnishes and Glass. Phone: Mutual C55-121.

Torches—UNIVERSAL TORCH & MANUFACTURING CO., 130 East 24th St.

FAIRPORT HARBOR, O.

Supplies—LAWRENCE, E. E., Jr., Marine Merchandise and Supplies. Phone: 847-W. Night and Sunday Phone: No. 1184-W.

FORT WILLIAM, ONT., CAN.

Coal—MURPHY, JAMES, Kaministiquia River.

Repairs—NORTHERN ENGINEERING & SUPPLY CO., LTD., Myles St. Full line of Engineering and Marine Supplies.

Day or Night Estimates Cheerfully Given

G. FICKENWORTH

Electric Welder and Air Compressor on Tug

Boiler Repairing and Forging, Pipe Work
Marine and Hull Work a Specialty
Machine Work

Shop Phone C-51-943 Residence Phone 55-177
Foot of French St., Erie, Pa.

ACME BOILER WORKS, Inc.

EXPERT BOILERMAKERS

Marine Work a Specialty

Phone: Cedar 1148 - 1149

Nights and Sundays Longfellow 3244
Fairmont 5743R

Junction at Jefferson Ave., Detroit, Mich.

Mutual 23-846

National Boiler Works

FOOT PEACH STREET, ERIE, PA.

Boiler And Hull Repairing—Blacksmithing

Electric and Acetylene Welding

Welders On Trucks and Boats

Night and Sunday Calls

D. J. MARTIN

75-225

GODERICH, ONT., CANADA

Meats—BAKER & AINSLIE, Marine Meat Market, Bedford Block, Dealer in Fresh and Cured Meats. Vessel Supplies our Specialty. Orders delivered promptly anywhere in the city. Phone No. 21; House Phone 310.

HAMILTON, ONT., CANADA

Packings—GARLOCK PACKING CO., THE, 200 Queen St., North.

Wire Rope—GREENING, B., WIRE CO., LTD., THE. Wire rope for Snubbing and Unloading.

HARTFORD, CONN.

Packing—COLT'S PATENT FIRE ARMS MFG. CO.

HOMESTEAD, PA.

Valves—HOMESTEAD VALVE MANUFACTURING CO.

HURON, O.

Supplies—HENES & WILKES, Successors to E. E. Cook, 1st door north of Post Office. Groceries and Hardware.

INDIANA HARBOR, IND.

Marine Supplies—CALUMET MARINE SUPPLY, 2311—136th St.

INDIANAPOLIS, IND.

Pumps—DEAN BROTHERS COMPANY, 323 W. Tenth St.

LORAIN, O.

Coal—LORAIN COAL & DOCK CO., THE.

Provisions—McHENRY, CHAS. N., 339-341 E. Erie Ave. City and Marine Meat Market and Grocery. Phone: 8134 day and night.

Repairs—BRUNK MACHINE & FORGING CO., THE, 947-53 Broadway. Phone 4275. Res. Phone: 3109.

Bell Phone, Seneca 0933 Night Phone, Abbott 0418-J

Oldman and Magee Boiler Works, Inc.

**Boilers, Tanks, Stacks, Structural
Work and Castings**

Boiler Repairing Promptly Attended to
Day or Night

*Marine Work a Specialty
Electric Welding*

Works, 32-42 Illinois Street
Buffalo, N. Y.

Residence Mut. Phone 24866 F. J. TOLLON Shop Mutual Phone 24893
Call Nights or Sunday

American Boiler Works Electric Welder on Tug

With Air Compressor and Acetylene Outfit
Boiler, Engine and Hull Repairing, Cleaning and Welding Safe Ends on Boiler Tubes, promptly attended to, night or day. Builders of Marine, Stationary & Portable Boilers. Tugs & Scows.
Works: Front and State Streets Erie, Pa.

Phone Broadway 499 Night Phone Hanover 1518
" " Grand 1583

THE MURPHY BOILER COMPANY

153-157 Barclay Street
Milwaukee, Wisconsin

Boiler and Hull Work a Specialty
Electric and Oxy-Acetylene Welding Plants

MANITOWOC, WIS.

Provisions—MANITOWOC MARINE GROCERY, John G. Zaczek, Proprietor. 7th & Marshall Sts. We have everything. Phones: 70 and 760. Night Phone: 760.

Shipbuilders—MANITOWOC SHIPBUILDING CORPORATION, Designers and builders. Complete Dry Docking and repair facilities for repairing Hulls, Boilers and Machinery. Full line of Oils, Grease, Packing and other engine room Supplies.

MARQUETTE, MICH.

Lake Coal—SPEAR, F. B., & SONS, Anthracite, Smokeless, Bituminous. Cement, Gravel, Sand.

**MIDLAND-TIFFIN-PORT
McNICOLL-CANADA**

Laundry—MIDLAND STEAM LAUNDRY CO., LTD., OF MIDLAND-PORT McNICOLL. We make a specialty of returning Steamer Laundry the same day if required. "As good as the best" is our motto. Telephone 36 Midland and a driver will call.

MILWAUKEE, WIS.

Boilers—MERTES-MILLER CO., THE, 239-241 Pittsburgh Ave.

Engineers Supplies—SAEFKE & NIENOW COMPANY, 222 Fourth St. Office Phone Grand 3488.

Packings—GARLOCK PACKING CO., THE, Plankinton Bldg.

Shipbuilders—MILWAUKEE DRY DOCK COMPANY, Foot of Washington St. Telephones: Hanover 3 and 4.

Welding—MURPHY BOILER CO., THE, 153-157 Barclay St. Electric and Oxy-Acetylene welding. Boiler and Hull work a specialty. Phone Hanover 499. Night Phone Hanover 1518 and Grand 1583.

**Northern Engineering & Supply Company,
LIMITED**

We have experienced men and necessary Plant equipment to do all kinds of High Class Marine Work, Welding and Cutting, Foundry Work, Sheet Metal Work, Pipe, Valves and Fittings. Full Line of Engineering and Marine Supplies.

GIVE US A TRIAL

Phone 650S

Night Phone S. 273

MYLES ST. FORT WILLIAM, ONT., CAN.**E. H. McGINIS**

Sheet Metal Work, Tanks,
Ventilators and General
Repair work.

Foot of French St., Erie, Pa.**THE TOLEDO FOUNDRY & MACHINE CO.****Location—Cherry and Water (at the Bridge)**

Service— Marine Repairs a Specialty (Day or Night) under personal supervision "Pete" Cowie. Grate Bars—All kinds in stock. Forgings—Pattern Making.

Phone— MAIN 4027**Toledo, O.**

NEW BRUNSWICK, N. J.

Refrigeration—BRUNSWICK-KROESCHELL CO.,
150 Jersey Ave.

NEW YORK CITY

Boiler Water Cleaner—FILTRATORS COM-
PANY, INC. Eliminates corrosion, pitting,
scale and oil.

Compositions (Protective)—RED HAND COM-
POSITION CO., INC., 1 Broadway.

Oil—VACUUM OIL CO., 61 Broadway.

Rope—WHITLOCK CORDAGE CO., 46 South St.

Rudders—OERTZ STREAMLINE RUDDER
COMPANY, 75 West St.

OGDENSBURG, N. Y.

Coal—HALL, GEORGE, CORPORATION.

Fish Market—McCORMICK, FRANK. McNaugh-
ton Market.

PALMYRA, N. Y.

Packings—CRANDALL PACKING CO.

Packings—GARLOCK PACKING COMPANY.

PHILADELPHIA, PA.

Engineers (Diesel) — BARRAJA-FRAUENFELD-
ER & CO., J., 1600 Walnut St.

Insurance—INSURANCE CO. OF NORTH
AMERICA, Third and Walnut Sts.

Packings—FRANCE PACKING CO. (Tacony).

PORT HURON, MICH.

Fuel—PORT HURON COAL & DOCK CO.,
Bunker Coal, accurately weighed in Hoppers
suspended on Fairbanks automatic scales.
Fast fueling, 24 hours per day. Best West
Virginia Coals. Located on St. Clair River
beside International Tunnel.

Paint (Canvas)—ROBESON PRESERVO CO.

Repairing—PIONEER BOILER WORKS, Elec-
tric Welding, Tanks and Stacks.

**REILLY AND G-R
MARINE AUXILIARIES**

Evaporators	Feed Water Heaters
Distillers	Fuel Oil Heaters
Oil Coolers	Grease Extractors
Filters, etc.	

Catalogues on request.

The Griscom-Russell Co.

285 Madison Ave., New York
Chicago Office - 835B Monadnock Bldg.

Paracoil**Equipment for Lake Vessels**

Feed Water Heaters	Fresh Water Stills
Grease Extractors	Steam Traps
Feed Water Filters	Condensers
Inspection Tanks	Oil Heaters and Coolers
Ash Ejectors, Etc.	

Write for Catalog

Davis Engineering Corp.

90 West Street — New York City
Factory—Elizabeth, N. J.

Great Lakes Representatives:

Wallene Engineering Co.

1783 E. 11th St., Cleveland, O.

SANDUSKY, O.

Repairs—KLOTZ MACHINE CO., 318 West Water St. Phone Main 36. Machinists, Blacksmiths, Patternmakers, Iron, Brass and Aluminum Founders. Special attention given to Marine repairs, DAY OR NIGHT.

SARNIA, ONT., CANADA

Hardware—MacKENZIE, MILNE & CO., LTD., Hardware, Engineers Supplies. Sheet Metal Work.

SAULT STE. MARIE, MICH.

Welding—KAINE BOILER & MACHINE WORKS, 326 Court St.

SOUTH CHICAGO, ILL.

Marine Supplies—CALUMET MARKET, 9237 Commercial Ave. Wholesale and retail. Meats, Groceries, Fruits, fresh Vegetables. Phone Regent 0200. Representative, Ben Sturm, Telephone Sag. 4330.

Shipbuilders—CHICAGO SHIPBUILDING COMPANY, 101st St. and Calumet River. Telephones: South Chicago 0780 and 0781.

SUPERIOR, WIS.

Electric Service Supplies and Repairs—BENSON ELECTRIC CO. We manufacture electric whistles, steering devices and rudder indicators and give day and night service on all electrical work. Telephone repairs a specialty. Phones: Broad, 1123; Nights, Broad 1874 or Broad 1926.

Laundry (Marine)—HAWKINS MARINE LAUNDRY, Duluth—Superior Harbor. Phones: Day, Broad 873; Nights, Broad 2273—3570J.

Shipbuilders—SUPERIOR SHIPBUILDING COMPANY, THE, Grand Ave. N. E., Corner 2nd St. Telephones: Broad 169 and Melrose 82.

Red Hand Compositions Co., Inc.

1 Broadway, New York, N. Y.



TRADE MARK

Anti-Corrosive Composition, First Coating. Hard Protective Composition, Second Coating FOR THE BOTTOMS OF LAKE SHIPS.

These paints cover a very large surface, are easy to apply, and have an enamel finish, thereby saving fuel and increasing speed.

*Manufacturers of Ships' Bottoms
Paints for over half a century.*

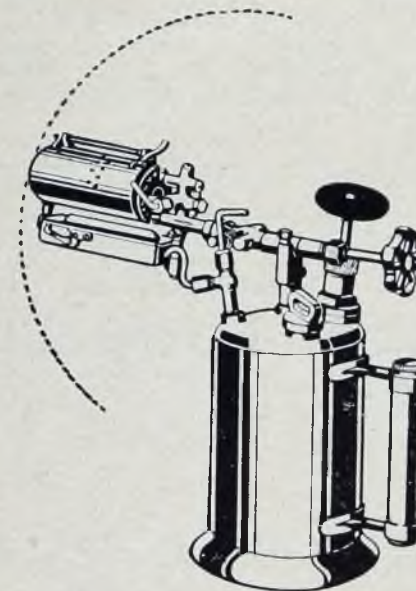

The Torch for every ship requirement
Universal Torch & Manufacturing Company
130 East 24th St. Erie, Pa.

SUPERIOR, WIS.—Continued

Supplies (Marine)—DULUTH MARINE SUPPLY CO., (A. R. Hallam & K. E. Hallam). Captains', Engineers' and Stewards' supplies. Erie, Vacuum, Standard and Enarco Oils. Day and night service. Phones: East 54—East 347.

TOLEDO, O.

Packing—MULTIPLEX PACKING & RUBBER CO., THE, 6 So. St. Clair St. Packing and Hose, all kinds and for all purposes. Phone: Adams 2552.

Repairs—TOLEDO FOUNDRY & MACHINE CO., THE, Cherry and Water (at the Bridge). Day or night service. Phone: Main 4027.

TORONTO, ONT., CANADA

Packings—GARLOCK PACKING CO., THE, 9 Foy Bldg., 32 Front St., W.
Supplies (Marine)—KIRBY & COMPANY, 50 Lake St., Phone Elgin 4512.

TWO HARBORS, MINN.

Meats—MARINE MEAT MARKET.

WEST FORT WILLIAM, ONT., CANADA

Hardware—PIPER HARDWARE CO., 1515 Brown St.



EN-AR-CO MARINE LUBRICANTS

Quality — Service

*Stocks at all principal
Great Lakes Ports*

The National Refining Co.
 Marine Dept.
 Cleveland, Ohio

*What do you want to sell?
What do you want to buy?*

Satisfy your wants — no matter what they may be— by making them known to the readers of

MARINE REVIEW

Every issue carries many classified advertisements of interest and this service is one which every marine man can use to advantage. The Classified-ad section receives instant and careful attention and the service is at your command.

RATES: For Sale and Wanted: minimum ad, 30 words \$3.00, each additional word 10c. Help Wanted: minimum ad 50 words \$3.00, each additional word 6c.
Positions Wanted: minimum ad 25 words \$1.00, each additional word 4c.

MARINE REVIEW

Penton Bldg.

Cleveland, O.

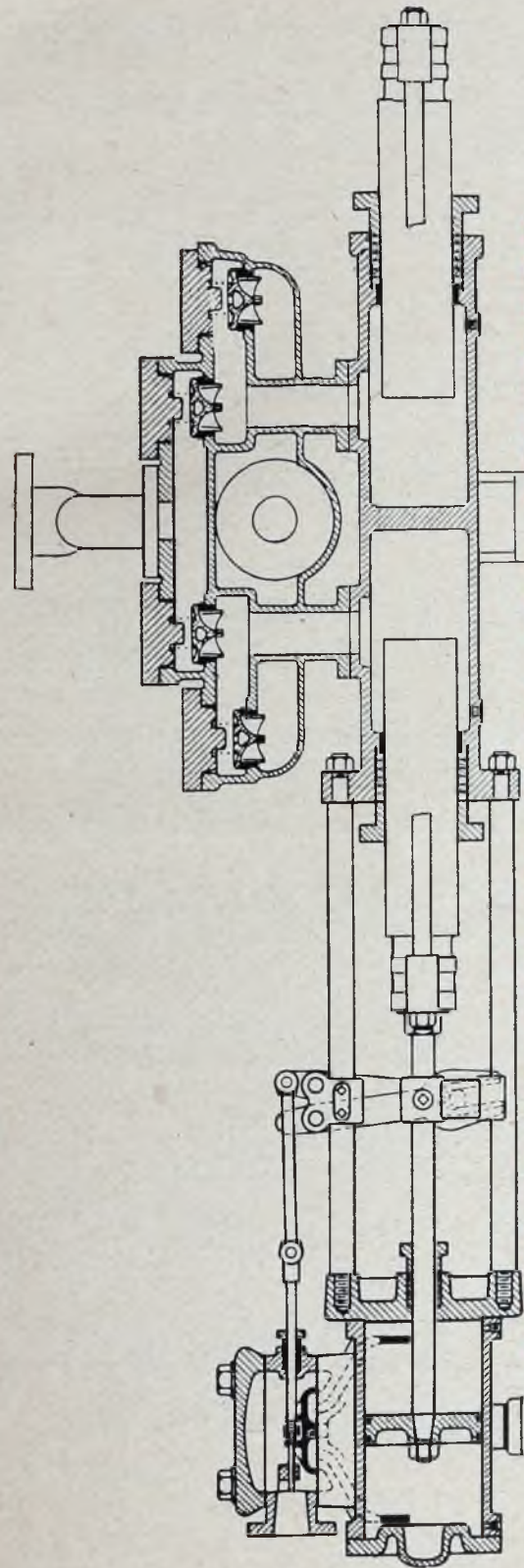

SUPERIOR PUMPS FOR ALL SERVICES

ESTABLISHED 1869

DEAN BROS. COMPANY

CAT.
126

WRITE
FOR

INDIANAPOLIS /IND.

J. BARRAJA-FRAUENFELDER & CO.
CONSULTING DIESEL ENGINEERS

RESEARCH WORK, DESIGNS,
SPECIFICATIONS, APPRAISALS
ESTIMATES

INDUSTRIAL AND MARINE
INSTALLATIONS

Diesel Problems Analyzed and Developed.
Applications to Railroad Work.

NEW YORK
60 Broadway

PHILADELPHIA
1600 Walnut Street

ELECTRIC SERVICE

SUPPLIES AND REPAIRS

Phone your needs and we
will take care of you

BENSON ELECTRIC CO.

Cor. 3rd and Grand, Superior, Wis.

Day Phones { Broad 1123
 or
 Melrose 1124

Night Phones { Broad 1874
 or
 Broad 1926



Marine Oils

A grade for each type of service

**Dependable
Lubrication**

Daily ships wend their way through winding harbor channels, discharge cargoes and take on supplies. One supply in particular must always be available when wanted, must always be of the correct grade and always uniform and dependable in quality. That indispensable supply is scientifically correct marine oils.

Gargoyle Marine Oils are manufactured to meet scientifically the exact lubricating requirements on board the ship. There is a correct grade for each type of service and each grade is uniform and dependable in quality.

At any port you name, your needs can be filled by a representative of the Vacuum Oil Company who will be glad to get in touch with you.

VACUUM OIL COMPANY

New York, U. S. A.

TORONTO, CANADA

**Captains and Engineers
Supplies**

Beldam's Packings

Kirby & Company
50 Lake St.

Phone Elgin 4512

PIPER HARDWARE CO.

Paints, Rope, Cable, Packing,
Valves, and Pipe Fittings.

1515 Brown St., West Fort William, Ont.
Phone—S. 741

SERVICE OUR SPECIALTY

MUTUAL PHONE— C55 - 121

A. H. BREBNER & SON

Steamboat and Engineer's Supplies
Paints, Oils, Varnishes and Glass
Plumbing and Tin Work

MARINE AGENTS
VACUUM OIL CO.

16 EAST 5TH STREET
ERIE, PA.



Marine Paints and Varnishes

Manufactured by

The Ferbert-Schorndorfer Co.
Elmwood Ave. and Berea Rd.
Cleveland, Ohio

C. M. LANE LIFEBOAT CO., INC.

Oldest Lifeboat Builders—Known The World Over

Life Boats — Life Rafts — Life Floats

Motor Boats and Work Boats

Metallic and Wood

856 Humboldt St. Brooklyn, New York

When your ship arrives at South Chicago
for the best Meats, Groceries, Fruits and
Vegetables go to

CALUMET MARKET

9237 Commercial Ave.

Supplying Steamships, Hotels and Restaurants

9 Phones—Regent 0200 Res. Phone Sag. 4330

THE Fries and Schuele COMPANY

Foremost out-fitters on the Great Lakes

SERVICE & SAVINGS

on

Beddings

Linens

Curtains

Floor Coverings

Telephone, Atlantic 4340

West 25th St., Cleveland,

"Steer to the big red sign"

Specializing in Marine Work

The Real Family Laundry Co.

CLEVELAND, OHIO

5710 Superior Avenue, Phone, Randolph 0218

Please Remember to USE

Harvard Oil Soap

**Harvard Work Easy
Soap Powder**

Harvard Liquid Soap and Jars

THE HARVARD MFG. CO.

4307 Woodbine Ave. CLEVELAND



Leopold Brothers Furniture Co.

Lorain at W. 30th

Telephone: Melrose 2324

Cleveland, O.

Steamboat Furniture

Draperies

Carpets

Bedding

39 Years of Service and
Satisfaction

Phones: 404, 504

THE ELECTRIC LAUNDRY CO.

Laundry, Carpet Cleaning, Dyeing and
Dry Cleaning for the Marine
Trade a Specialty

Mrs. Geo. Close, Mgr.

ASHTABULA, OHIO

TWIN PORTS

When in Twin Ports give us a call for your
laundry. Launch and Truck service. Day or
night.

The Old Reliable

HAWKINS MARINE LAUNDRY

Superior, Wisc.

Phone: Broad 873

Nights: Broad 2273

5th Successful Year

CALUMET MARINE SUPPLY

2311—136 St. All Phones 802

DAY OR NIGHT

INDIANA HARBOR, IND.

We Supply Vessels at Buffington

Phone 42-196

Res. Phone 43-487

Fred C. Meiser

New Location

29 East 7 St.

Dealer in Fresh, Salt, Smoked Meats and
Fish, Ice, Milk, Poultry

Erie, Penna.

Carl Meiser, mgr.

Day and Night
Launch Service

Marine Meat Market

Dealer in

MEATS, GROCERIES, FISH,
POULTRY, MILK, ICE, etc.

H. B. Puent, Manager Telephone: 174

Residence Phone: 52

TWO HARBORS, MINN.

FRANCE METALLIC PACKING

For all Conditions of Marine Service

Send for Catalog and List of Users

FRANCE PACKING CO.

Tacony, Philadelphia, Pa.

CRANDALL PACKING On Great Lakes

For quick packing service get in touch
with our nearest branch office located con-
veniently at

Chicago
Tel. Main 3203

Cleveland
Tel. Superior 1077

Detroit
Tel. Randolph 1276

Let us send you catalog

CRANDALL PACKING CO.

O. J. Garlock, Pres.
Main Office and Factory
Palmyra, N. Y.

**20th Century Metallic Packing
Martell Metallic Packing**

We can, and we do give Lake Boats the very best packing, also the very best service. Our location makes this possible.

Details on Request

THE MARTELL PACKINGS CO.

Elyria, Ohio

SANDERS, DUDLEY & CONNELLY
ATTORNEYS AT LAW

HARRY D. SANDERS	1142 MARINE TRUST
DONALD S. DUDLEY	BUILDING
WILLIAM M. CONNELLY	BUFFALO, NEW YORK
	SENECA 5822

Melrose 780

Duluth Marine Supply Co.

Complete Outfitters of Ships
Day and night Service

SIMON CLARK	Foot of Fifth Avenue West
Manager	DULUTH, MINN.

Quaker Marine Products

P. P. P. ROD PACKING
EBONITE SHEET PACKING
EBONITE STOP VALVE PACKING
PUMP VALVES, GASKETS,
RUBBER MATS
RUBBER HOSE for all purposes

Dealers in every Lake Port

QUAKER CITY RUBBER CO.
MAIN OFFICE—PHILADELPHIA

BRANCH—217 W. Huron St., Chicago
Phone: Dearborn 1914



A metal Packing requiring no change of gland, and when used on good conditions, will give years of service with no wearing, scoring or pitting. Requires no attention, laying up, or fitting out. Ask your dealer to supply you.

The Conneaut Packing Co.
Conneaut, Ohio

We Furnish Best Quality

Steamboat Fuel

at

LORAIN, OHIO

From Lighter or Car
Dump at all Times

The Lorain Coal & Dock Company COLUMBUS OHIO

Branch Office
914 Union Trust Bldg. Cleveland, Ohio

**FUEL
LIGHTERS**

PICKANDS, MATHER & CO.

AT BUFFALO, ASHTABULA AND CLEVELAND

Best
Quality
Coal
furnished
at any
time
during
Day
or
Night

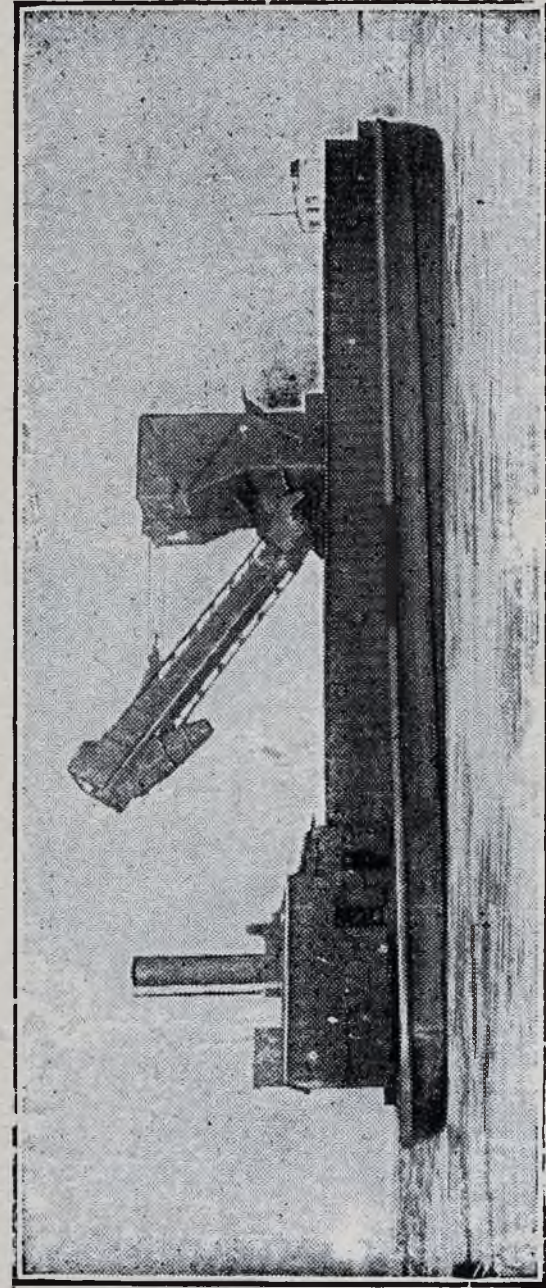

At
Detour,
Mich.,
A new
Concrete
Fuel
Dock
equipped
with
Chute
Capacity
of 2,000
tons

Steel Fuel Lighter West Shore. Capacity 500 tons per hour

CLEVELAND, OHIO

Union Trust Building

Marine Review

Cleveland, Ohio

A practical, illustrated monthly paper for the man who wants to know what is going on in the marine world.

It covers ship operation, shipbuilding, marine engineering, development of docks and terminals, describes the new vessels, prints all the news of the trade, and is packed with useful suggestions for everyone connected with this great and growing industry.

The subscription price is only \$3.00 a year. We will be glad to send a free sample copy to anyone who is interested.

FUEL DOCKS

*Service at Any Hour
in Any Quantity*

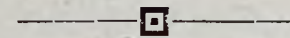

George Hall Corporation

Ogdensburg N. Y.
Phone 311 and 60

JAMES MURPHY

**Steamboat Coal Fueling
Facilities**

We furnish only the best grades of Pittsburgh
& Youghiogeny Steam Coal.
KAMINISTIQUIA RIVER, FORT WILLIAM, ONT.
Phone South 8

Anchor Coal Company

Bunker Coal

Bituminous and Anthracite Coal

Foot of Holland St. Erie, Pa.

Pittsburgh Coal Company

General Offices:

Henry W. Oliver Building,
Pittsburgh, Pennsylvania
Lake Shipping and Fuel
Department,
Terminal Tower Building
Cleveland, Ohio

Our Soo River Fuel
Dock, Lime Island
and Detroit River
Fuel Dock, Sandwich
—Fastest and Most
Convenient Plants
on the Great Lakes.

Fuel Lighters and Loading Docks at
Cleveland & Ashtabula
Detroit River Fuel Docks at
Sandwich, Ontario
Sault River Fuel Docks
at Sault Ste. Marie & Lime Island,
Michigan

We handle only the best grades of
Pittsburgh and Youghiogeny coal

Steamboat Fuel

at

TOLEDO

COAL OF BEST QUALITY

furnished by

LIGHTER

or Direct from the

DOCK

at all times

The Ironville Dock & Coal Company

Leader Building
CLEVELAND, O.

Ironville Dock
TOLEDO, O.

BOAT

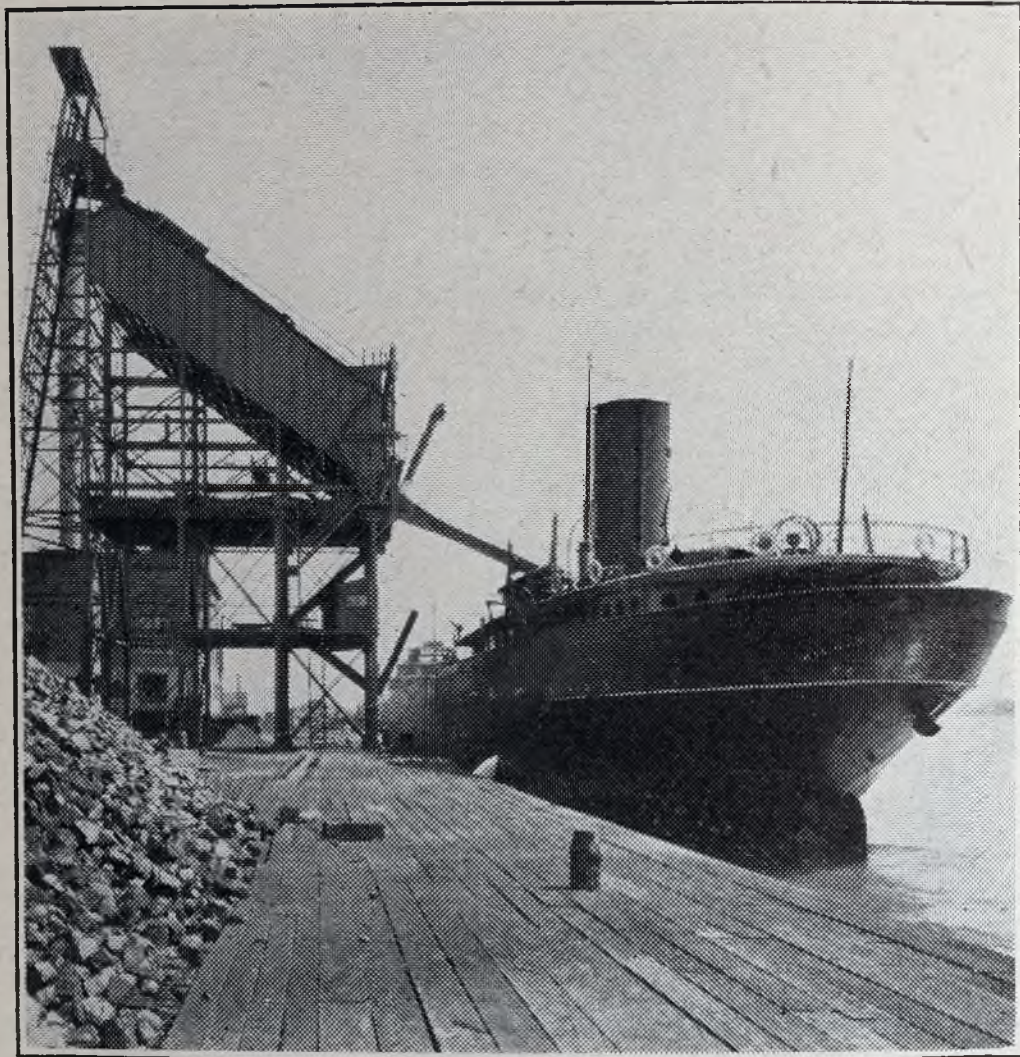

William G. Mather fueling at our dock

PORT HURON COAL
PORT HURON,
 Executive Offices 1460 Union

FUEL

MODERN FUEL DOCK

LOCATED CONVENIENTLY
 on St. Clair River beside
 International Tunnel.

BEST WEST VIRGINIA COALS
ACCURATELY WEIGHED

Bins rest on Fairbanks auto-
 matic scales.

FAST FUELING
24 HOUR SERVICE

& DOCK COMPANY
MICHIGAN
 Trust Bldg., Cleveland, Ohio

Index to Advertisers

A

Acme Boilers Works, Inc.....	187
American Boiler Works	189
American Ship Building Co.....	223
Anchor Coal Co.	213
Anchor Packing Co.....	28

B

Baker & Ainslie	188
Baker, Howard H., & Co.....	178
Banner, Thomas B., Boiler & Welding Co.....	181
Barraja-Frauenfelder, J., & Co.....	200
Beckman, Henry, & Son	186
Benson Electric Co.....	200
Boom Boiler & Welding Co.....	179
Brebner, A. H., & Son.....	202
Brooks Oil Co.	222
Brown, Ely & Richards	176
Brunk Machine & Forging Co.....	188
Brunswick-Kroeschell Co.....	36
Buffalo Dry Dock Co.....	178

C

Calumet Marine Supply Co.....	206
Calumet Market	203
Cassco Bar-Metallic Packing Co.....	26
Central National Bank	10
Chicago Ship Building Co.....	194
Christensen, William	174
Cleveland Steam Gauge Co.....	180
Colt's Patent Fire Arms Mfg. Co.....	30
Commonwealth Boiler Repair Co.....	175
Conneaut Packing Co.	209
Consaul-Hall Co., Inc.....	3
Crandall Packing Co.	207

D

Davis Engineering Corp.	193
Dean Brothers Co.	199
Detroit Shipbuilding Co.	184
Duluth Marine Supply Co.....	208

E

Electric Laundry Co.	205
Erie Machine Shops	46

F

Ferbert-Schorndorfer Co.	203
Fickenworth, G.	187

Filtrators Co.	16
Ford Brothers	176
France Packing Co.	207
Fries & Schuele Co.	204
Frontier Engine Works, Inc.....	176

G

Garlock Packing Co.	24
Garratt-Callahan Co.	18
Geary Boiler Works	174
Gehm, John	176
Greening, B., Wire Co., Ltd.....	14
Goulder, White & Garry	182
Griscom-Russell Co.	193
Gunn, P. J.	176

H

Hall, George, Corp.	213
Harvard Mfg. Co.	204
Hausheer & Sons Co.	182
Hawkins Laundry Co.	205
Henes & Wilkes	188
Homestead Valve Mfg. Co.....	34

I

Insurance Company of North America.....	8
Ironville Dock & Coal Co.....	215

K

Kaine Boiler & Machine Works	185
Karpel, Mrs. Max	174
Kelley, David & Cottrell	182
Kirby & Co.	202
Klotz Machine Co.	194

L

Lake Erie Mfg. Co., Inc	22
Lane, C. M., Life Boat Co.	203
Lawrence, E. E., Jr.	186
Leopold Brothers Furniture Co.....	205
Lorain Coal & Dock Co.....	210

Mc

McCormick, Frank	192
McGinis, E. H.	191
McHenry, Charles N.	188
McKinnon Iron Works Co.....	174

M

Mackenzie, Milne & Co., Ltd.....	194
Manitowoc Marine Grocery	190

Index—(Continued)

Manitowoc Shipbuilding Corp.....	44
Marine Iron & Ship Building Co.....	42
Marine Meat Market	206
Martell Packing Co.	208
Meiser, Carl C.	206
Mertes-Miller Co.	185
Midland Steam Laundry Co., Ltd.....	190
Midwest Engineering & Equipment Co.....	40
Milwaukee Dry Dock Co.....	190
Multiplex Packing & Rubber Co.....	196
Murphy, James	213
Murphy Boiler Co.	189

N

Nagle & O'Day	176
National Boiler Works	187
National Refining Co.....	197
Nicholson & Hall Boiler & Welding Corp....	178
Northern Engineering & Supply Co.....	191

O

Oertz Streamline Rudder Co.....	173
Oldman and Magee Boiler Works, Inc.....	189

P

Phoenix Ice Machine Co.....	38
Pickands, Mather & Co.....	211
Pioneer Boiler Works	183
Piper Hardware Co.	202
Pittsburgh Coal Co.....	214
Port Huron Coal & Dock Co.....	216-217

Q

Quaker City Lumber Co.....	209
----------------------------	-----

R

Real Family Laundry Co.....	204
Red Hand Composition Co., Inc.....	195
Rennick, Thomas J.	174
Robeson Preservo Co.	12
Root & McBride Co.	4
Rosner Boiler Works	177
Rud Machine Co.	185
Russell & Watson, Inc.....	48

S

Saefke & Nienow Co.	32
Sanders, Dudley & Connelly	208
Smith Brothers	180
Society for Savings	6

Spear & Sons, F. B.	190
Spencer & Spencer	184
Superior Shipbuilding Co.....	194

T

Tashenberg Bros. Boiler Works.....	183
Thompson-Haynes Co.	180
Thomson, J. & A.	182
Toledo Foundry & Machine Co.....	191
Trout, H. G., Co.	176
Turner's Drug Store	171

U

Universal Torch & Mfg. Co.....	195
Upson-Walton Co.	Back Cover

V

Vacuum Oil Co.	201
---------------------	-----

W

Wakefield Boiler Compound Co.....	20
Welsh Oil Co.	221
Whitlock Cordage Co.	2
Whitright, H. A.	174

EFFICIENT, DEPENDABLE LUBRICATION

OILDAG STEAM CYLINDER OIL
OILDAG MOTOR LUBRICANT
GREDAG GREASES
MONARCH OILS

ACHESON PURE POWDERED GRAPHITE

WELSH OIL CO.

Oildag and Gredag Distributors

3277 WASHINGTON BLVD.
CLEVELAND, OHIO

PHONE:

FAIRMOUNT 1941



The Drum

with the

“Red Band”

— CONTAINS —

“Brooks Boiler Metal Treatment”

Removes and Prevents
Scale

Stops Rusting, Pitting &
Corrosion

Will not cause boilers to
foam

Cannot be beat for Marine
use

Supplied at all Ports

Manufactured by

The Brooks Oil Co.

Cleveland, Ohio

H. L. Gates, *Marine Representative*
914 Union Trust Bldg., Cleveland

**THE
AMERICAN SHIP BUILDING
COMPANY**

GENERAL OFFICES

and

CLEVELAND PLANT

Foot of West 54th St., N. W.
Cleveland, Ohio

Telephone, Evergreen 2280

Night Telephones:

Gate, Evergreen 2277

Machine Shop, Evergreen 2776

Office, Evergreen 3089

LORAIN PLANT

Colorado Avenue, Lorain, Ohio
Telephone, Lorain 8112

SUBSIDIARY COMPANIES

BUFFALO DRY DOCK COMPANY

191-301 Ganson St., Buffalo, N. Y.

Telephones, Seneca 4055 & 4056

CHICAGO SHIP BUILDING COMPANY

101st St. and Calumet River, South Chicago, Ill.

Telephones, South Chicago 0780 & 0781

DETROIT SHIPBUILDING COMPANY

Foot of Orleans St., Detroit, Mich.

Telephone, Randolph 6900

MILWAUKEE DRY DOCK COMPANY

Foot of Washington St., Milwaukee, Wis.

Telephones, Hanover 3 & 4

THE SUPERIOR SHIPBUILDING COMPANY

Grand Ave., N. E., Corner 2nd St., Superior, Wis.

Telephones, Broad 169 and Melrose 82

C. D. Johnson



Ship Chandlery

Vessel Outfits

Wire and Manila Rope

Nautical Instruments

The Upson-Melton Co

CLEVELAND, O.

NEW YORK — CHICAGO — PITTSBURGH